

Bent Preferences: Network-Induced Motivation

For text on this session,
see *Neighbor Networks*,
Chapters 2 to 4, 8, and
Appendix G.

Appendices:

- I. Closure Stability Effects Spill Over between Neighbor Networks (from *Neighbor Networks*)
- II. Detail on Relative Advantage and Relative Deprivation (from *Neighbor Networks*)
- III. Relative Income Hypothesis in Economics (from *Neighbor Networks*)
- IV. Detail on Grinblatt, Keloharju, and Ikäheimo (from 2008, *Review of Economics and Statistics*)
- V. Detail on Emotion within Sentences (from *Neighbor Networks*)
- VI. Social Peers Defined by Structural Equivalence (from *Neighbor Networks*)

This handout was prepared by Ron Burt as a basis for discussion in executive education (Copyright © 2024 Ronald S. Burt, all rights reserved).
To download work referenced here, or research/teaching materials on related topics, go to www.ronaldsburt.com.

A Problem: the Agency Question (or Reputation Cost)

Spillover evidence on information access versus process by-product
Network mechanism for brokerage is local and personal, emphasizing agency

A Solution: Psychophysics in Social Context

Social networks define peers, and by so doing, predictably distort preferences
Bent preferences recover a classic concept yet preserve discipline foundations

Evidence: Network Fear & Brokers Less Subject to It

Loss is amplified to painful and quick — in distinct, closed networks
(structural equivalence, e.g., highway experiment, finalists in competition, or cohesion, e.g., members of elite team)

NASCAR crashes (situational loss aversion)

Buying a New Car (loss emotion is sharp, but short-lived)

Brokers - Less Afraid of Cooperation with Strangers

Brokers - Less Afraid to Show Emotion

Brokers - Operating in a Broader Time Horizon

Remember from Sessions 1-2 "Brokerage" handout (pages 39-41):

Network Broker ↔ **Achievement**

(Q289) Bridging structural holes can improve the odds of achievement, but achievement improves the odds of bridging structural holes. We cannot say that network structure is always causal for achievement, but given supportive evidence from experiments with random assignment to networks, we believe it can be causal. **True** or False?

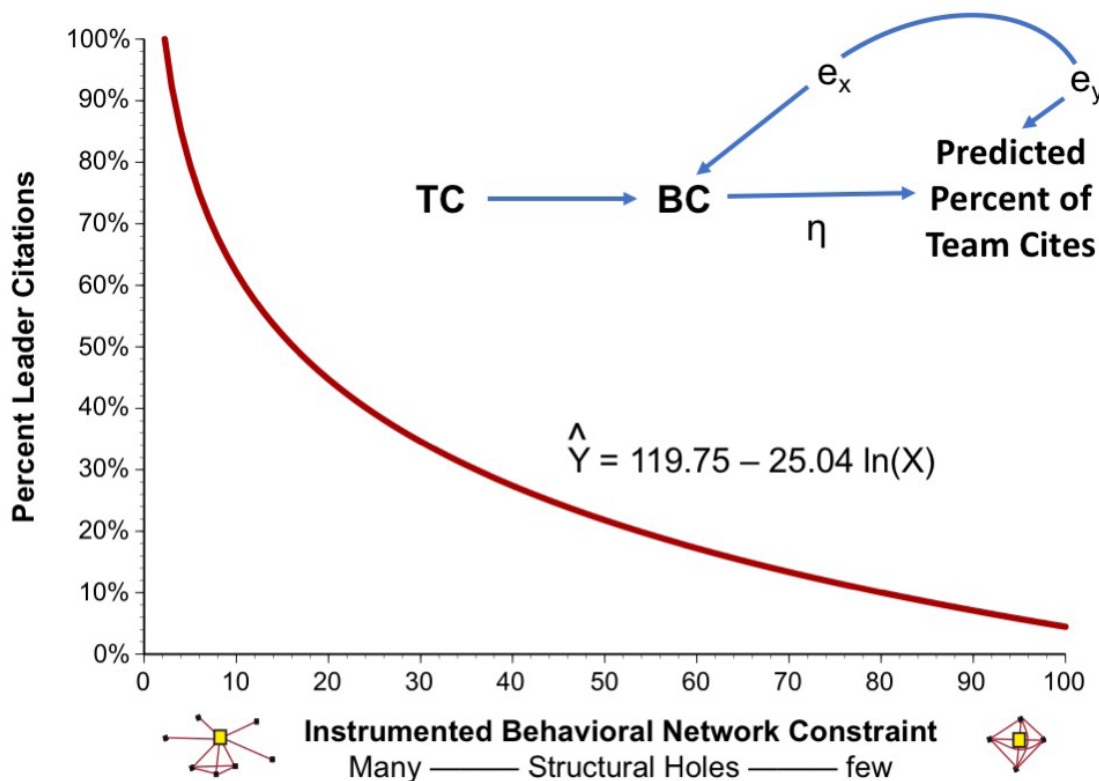

In other words, an increase in network constraint from 15 to 40 points triggers a 25% decrease in team recognition of one's leadership.

Graph-based AI model maps the future of innovation

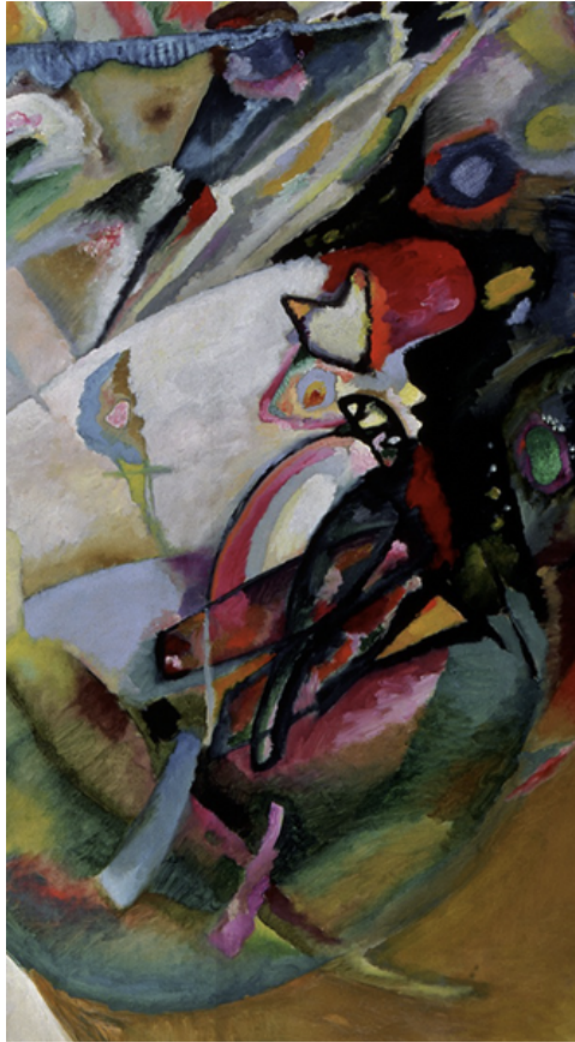

in current
issue,
2024
*Machine
Learning*



An innovative AI method developed by Markus J. Buehler, professor at MIT, bridges the gap between seemingly unrelated domains, such as biological tissues and Beethoven's "Symphony No. 9," by uncovering shared patterns of complexity and order. Using generative AI integrated with graph-based

Toward an improved causal test of network effects: Does alliance network position enhance firm innovation?

in current
issue, 2024
*Strategic
Management
Journal*

Exequiel Hernandez¹  | Jason K. Lee²  | J. Myles Shaver³ 

¹The Wharton School, University of Pennsylvania, Philadelphia, Pennsylvania, USA

²Hong Kong Baptist University, Kowloon, Hong Kong

³Carlson School of Management, University of Minnesota, Minneapolis, Minnesota, USA

Correspondence

Exequiel Hernandez, The Wharton School, University of Pennsylvania, Philadelphia, PA, USA.
Email: exequiel@wharton.upenn.edu

Funding information

Mack Institute for Innovation Management

Abstract

Research Summary: Assessing whether network position causes firm outcomes is difficult because networks result from firms' strategic choices. To address this issue, we develop a research design that separates self-driven network change from other-driven change. Because other-driven change suppresses the focal firm's agency, outcomes resulting from it can be interpreted as causal—under verifiable assumptions. We apply this method to reassess whether alliance network position affects firm innovation. Using data from the biotechnology industry, we find that structural holes (but not closure) increase firm innovation when self-driven network change is involved but *not* when other-driven change is involved. This raises two possibilities: network effects spuriously capture unobservable firm characteristics or network theories must be updated to account for agency.

Cannot Ignore the Agency Question

Cannot continue to avoid the question because agency seems to be critical — Spillover from adjacent networks indicates rate of decay in advantage from distant contacts. Decay is immediate (table), which implies that network advantage is not the result of advantaged access to information so much as a by-product of cognitive and emotional skills enhanced by managing the information in a network of diverse contacts. Individual reaction to network emerges as a critical performance variable. Social capital is a forcing function for human capital? (Coleman, 1988)

Study Population	Direct Contacts	Indirect Contacts
Asia-Pacific product launch	2.70	1.00
Supply-chain managers	4.17	0.92
HR employees	4.35	0.21
Investment bankers	3.43	1.50
Investment analysts	3.18	0.24

*Cells contain t-tests predicting employee performance in the row population from structural holes in the employee's network of direct contacts and holes between the employee's indirect contacts, with controls for job rank, function, location, and experience (Burt, 2009: Table 6.5). Observations vary from 258 to 469.

Agency has not been ignored so much as it has been put aside:

Assume It Away — Agency is a function of opportunity, so a network measure of opportunity is simultaneously a measure of probable action. All opportunities are developed subject to budget constraint (e.g., Buskins and van de Rijt, 2008; Reagans and Zuckerman, 2008), or the network ego has is an indicator of ego's preferences (e.g., Burt, 1992). Clearly wrong in that so many managers fall below their network potential.

Hold It Constant — Preference is defined by a personality or culture score, which is added to the performance prediction (e.g., Mehra, Kilduff and Brass, 2001; Xiao and Tsui, 2007). The burden of proof is attractive, but consistency is a problem. There are many personality measures, barriers to entry are low for new measures, and the data typically used to estimate performance associations with networks in an organization are prone to idiosyncratic correlations inconsistent across research projects (displayed personality is situation specific, Mischel, 2004).

discussed in pages 221-224 of *Neighbor Networks*

Shifting from Exogenous to Endogenous Agency

Individual Differences in Acting on Network Advantage

Person Exogenous to the Situation

Assume It Away

(e.g. Burt, 1992; Buskins & van de Rijt, 2008; Reagans & Zuckerman, 2008)

Hold It Constant

Capability controls for job-rank, function, experience, etc.
Personality score
(e.g. Mehra, Kilduff and Brass, 2001 ASQ)
Average scores across repeated measurements
(e.g. Epstein, 1979 JPSP)

Person Endogenous to the Situation

Add Situation to Personality Measures (Mischel 2004 ARP)

High variance within people across situations
(Mischel, 1968 book; quick summary in 1969 AP)
Extend personality to “if . . . then” interaction variables
if in situation A, then ego displays personality X, else
if in situation B, then ego displays personality trait Y
(CAPS model, “cognitive affective personality system,” Mischel and Shoda 1995 PR)
More empiricist than “hold it constant” solutions

Capture Person Separate from Situation, but Allow Individuals to React to Their Position in the Situation.

In other words, what a person sees depends on the situation from which it is seen. Psychophysics captures perception. Social network analysis captures the situation.

A Problem: the Agency Question (or Reputation Cost)

Spillover evidence on information access versus process by-product
Network mechanism for brokerage is local and personal, emphasizing agency

A Solution: Psychophysics in Social Context

Social networks define peers, and by so doing, predictably distort preferences
Bent preferences recover a classic concept yet preserve discipline foundations

Evidence: Network Fear & Brokers Less Subject to It

Loss is amplified to painful and quick — in distinct, closed networks
(structural equivalence, e.g., highway experiment, finalists in competition, or cohesion, e.g., members of elite team)

NASCAR crashes (situational loss aversion)

Buying a New Car (loss emotion is sharp, but short-lived)

Brokers - Less Afraid of Cooperation with Strangers

Brokers - Less Afraid to Show Emotion

Brokers - Operating in a Broader Time Horizon

A SOLUTION: Psychophysics in Social Context

**Begin with the
Psychophysics
of How People
Experience
Physical Stimuli**
(marginal utility, 1870s)

felt stimulation

$$= u$$

$$= \kappa X^v$$

$$= \kappa (\text{actual stimulus})^v$$

rate of felt stimulation increase

$$\partial u / \partial x = v u / x$$

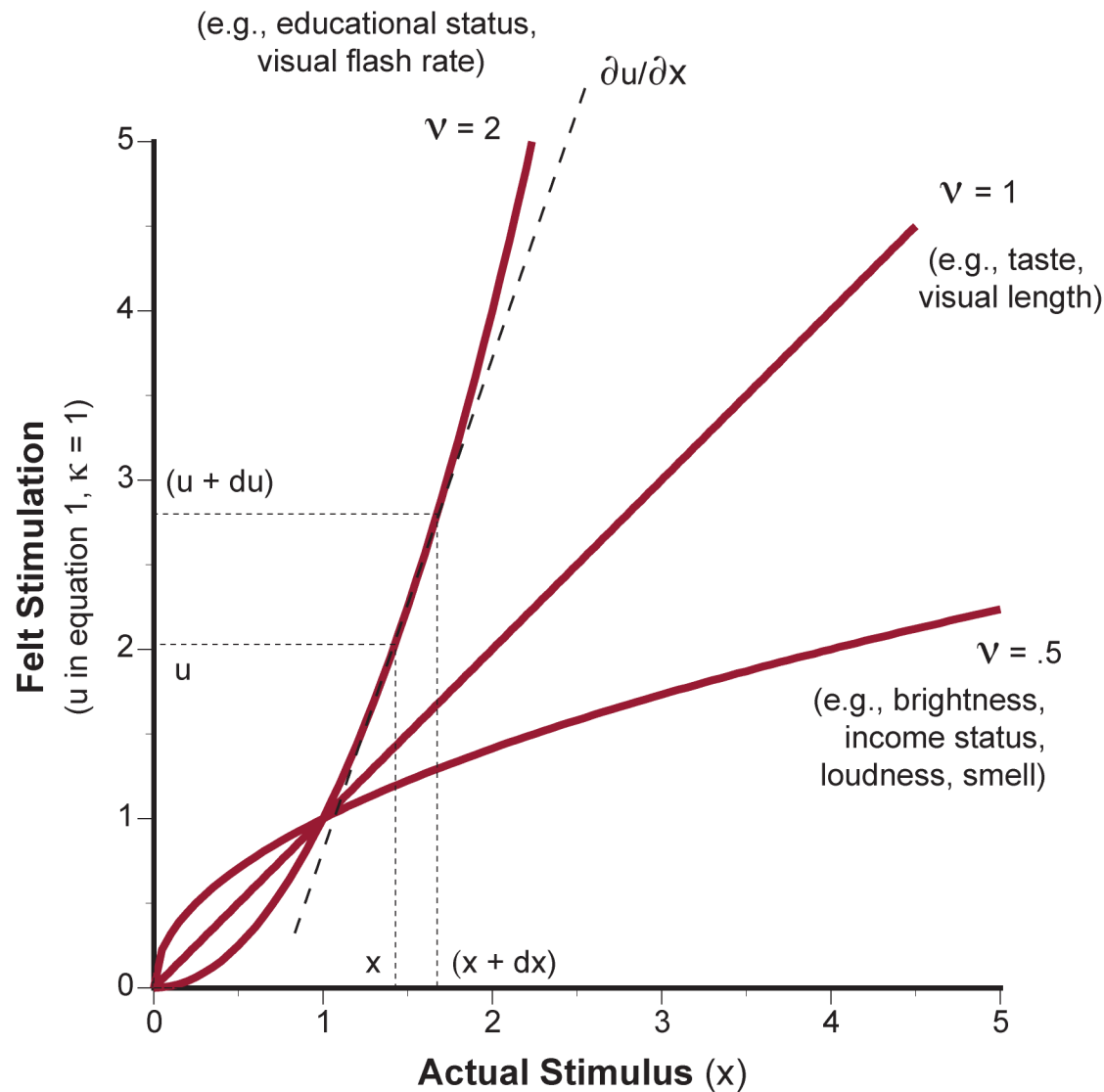

A PROBLEM: Social Comparison

Alain de Botton, TED 2009 Oxford
on “A kinder, gentler philosophy of success”



Alain de Botton is a Swiss writer, television presenter and entrepreneur. His books and television programs discuss various subjects in a philosophical style with an emphasis on their relevance to everyday life.

De Botton comes from a Jewish family, originating from a small Castilian town of Botton (now vanished) on the Iberian peninsula. His ancestors left in 1492 along with the rest of the Sephardic Jewish community and eventually settled in Alexandria, Egypt, where his father was born. His father, Gilbert de Botton, co-founded Global Asset Management. When his father died, his family was left a trust fund of over £200 million but for his part, de Botton lives solely off the proceeds of his book sales. De Botton lives in Shepherd's Bush in West London, with his wife Charlotte, whom he married in 2003, and their sons, Samuel and Saul. He has one sister, Miel, a psychologist in Paris.

De Botton spent his first eight years in Switzerland speaking French and German. He was sent to boarding school at the The Dragon School in Oxford, where he learned to speak English. He subsequently boarded at Harrow School. He achieved a double starred first in history at Gonville and Caius College, Cambridge and completed his masters degree in philosophy at King's College London. He began a Ph.D in French philosophy at Harvard University, but gave up research to write books for a general public. He had also been a PhD candidate at King's College London.

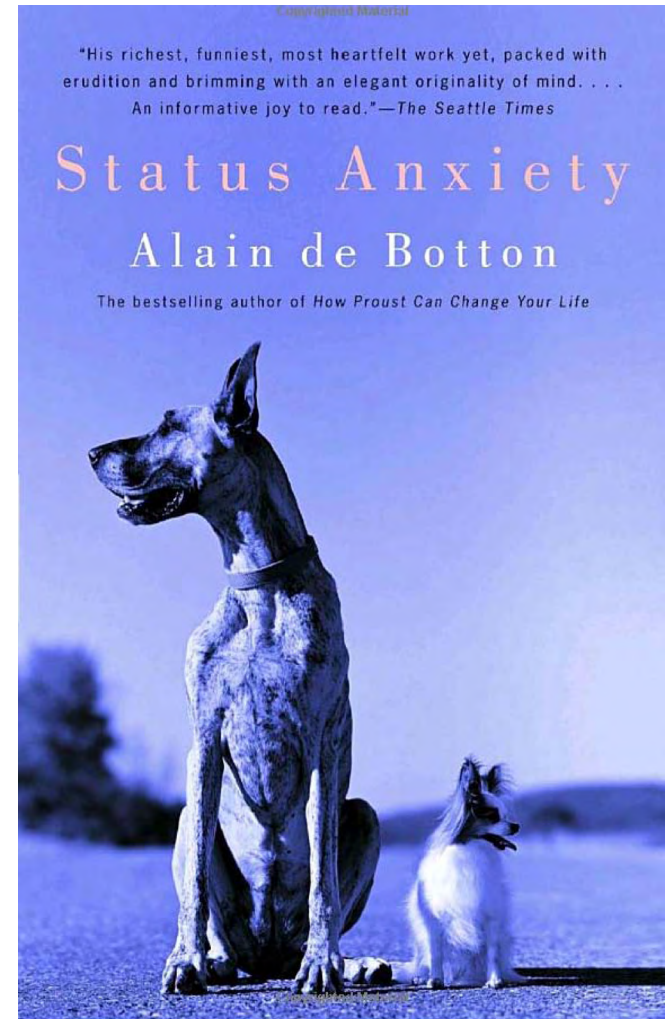

Who are the "peers" that define the benchmark for your evaluations of yourself? (colleagues and competitors; not the Queen.)

Imagine a fraction, w_{ij} ($0 \leq w_{ij} \leq 1$, $\sum_j w_{ij} = 1$) that measures the proportional extent to which contact j is person i 's peer within the surrounding network. (measurement in Appendix VI)

- competitors for the same promotion
- competitors for the same job
- competitors for the same sources of attention
- competitors for the same recognition

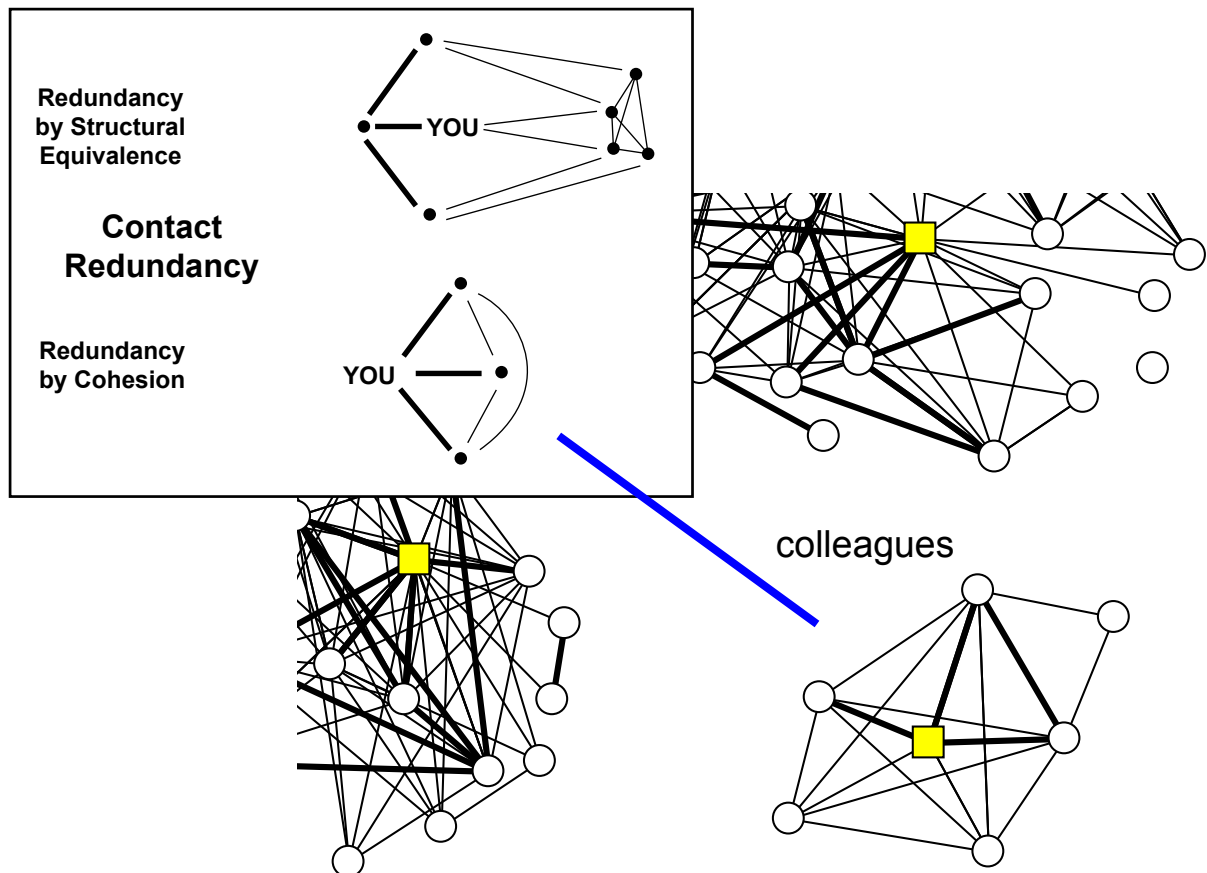

"Every time a friend succeeds, a little something in me dies." Gore Vidal, 1973 *London Times*

Then Put the Psychophysics of Individual Ego i in a Social Context of Peers j to Define "Bent Preferences"

Given the psychophysics of ego evaluating stimuli with respect to herself:

$$\frac{\partial u}{\partial x} = \frac{v u}{x} = \text{multiplier} \left(\frac{X_i^v}{X_i} \right)$$

$\frac{\text{what ego i currently feels}}{\text{actual stimulus to ego i}}$

Assume that her inter-personal evaluations result from the same mechanism when ego compares herself to peer j:

$$\frac{\text{what ego i currently feels}}{\text{actual stimulus to peer j}}$$

$$\text{multiplier} \left(\frac{X_i^v}{X_j} \right) W_{ij}$$

Network weight w_{ij} defines extent to which j is peer to i where $0 \leq w_{ij} \leq 1$, and $\sum_j w_{ij} = 1$.
not the Queen

multiplier = $v\kappa$, stimulus exponent times stimulus-measurement constant

Eq (4) in *Neighbor Networks*: $\partial U / \partial x_i = (v u / x_1) w_{i1} + (v u / x_2) w_{i2} + \dots + (v u / x_i) w_{ii} + \dots + (v u / x_n) w_{in}$

Equals psychophysics of individual for social isolate ($\partial U = \partial u$ if $w_{ii} = 1$).

Bent Preferences: Motivation and Inhibition

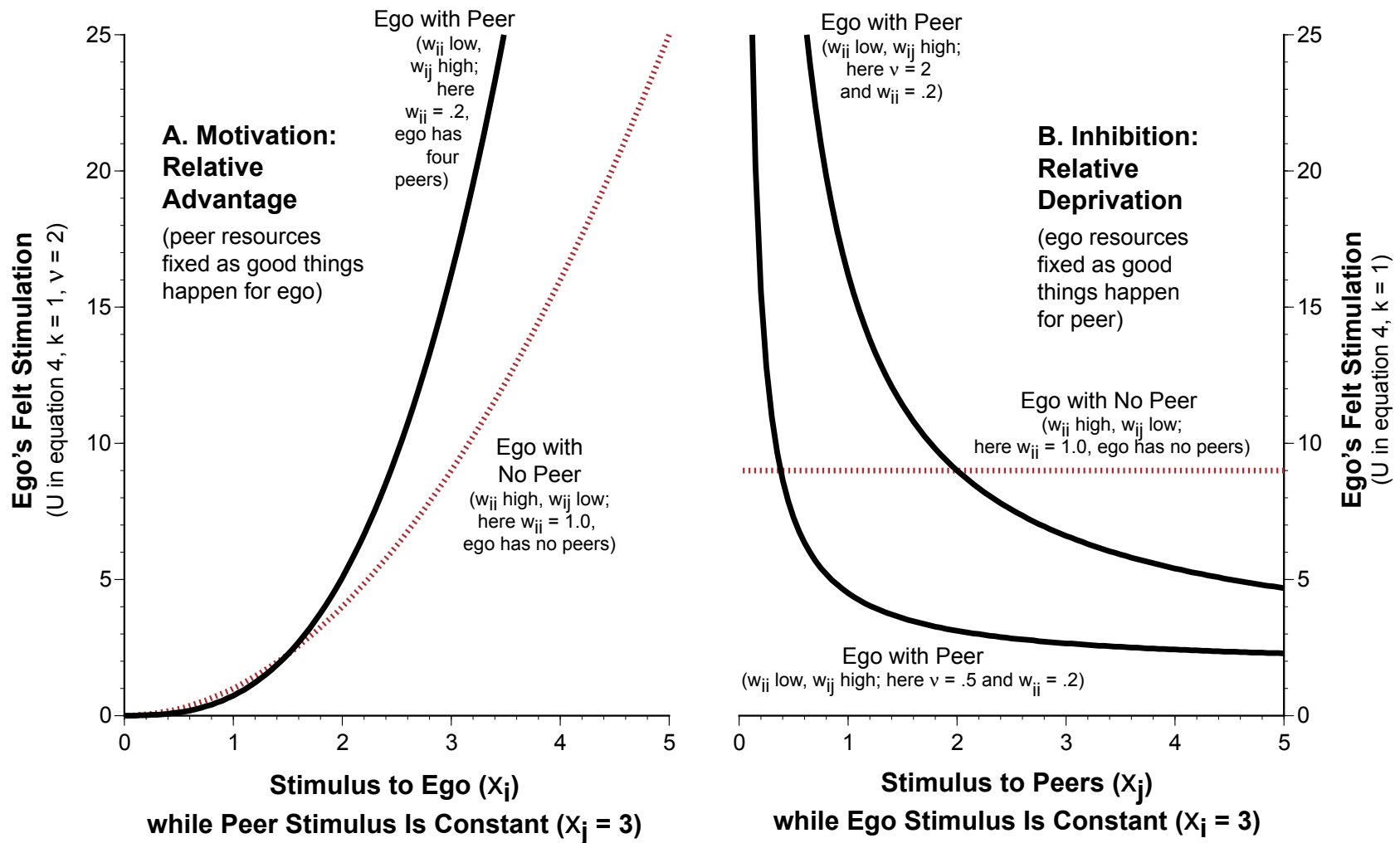

THE SIMPLE MODEL RECOVERS A CLASSIC CONCEPT: Motivation is based on perceptions predictably bent by social context as frame of reference, consistent with relative income in economics (Duesenberry, 1949; Appendix III of this handout), social comparison in psychology (Festinger, 1954), and relative advantage/deprivation in sociology (Stouffer et al, 1949). INTERDISCIPLINARY WORK: Plug & play compatibility with primary social science sources for network theory: economics (marginal evaluation, no interpersonal comparison of utility), psychology (psychophysics foundation, no transcendental group mind), and sociology (network defines peers, the social is again causal as in social psychology's "golden age").

from Figures 8.2 and 8.3 in *Neighbor Networks* (detail in Appendix II)

**To some extent,
fear of comparison
is generic to adults,**

Change one thing about your body.



Tim Brown, CEO of Ideo 2000-2019,
following David Kelly.



**but it is especially
severe in
situations where
our relative
performance is
especially obvious . . .**

(Q290) **Structurally equivalent people need not talk to each other directly, so how is it that they influence one another's opinions and decisions?**

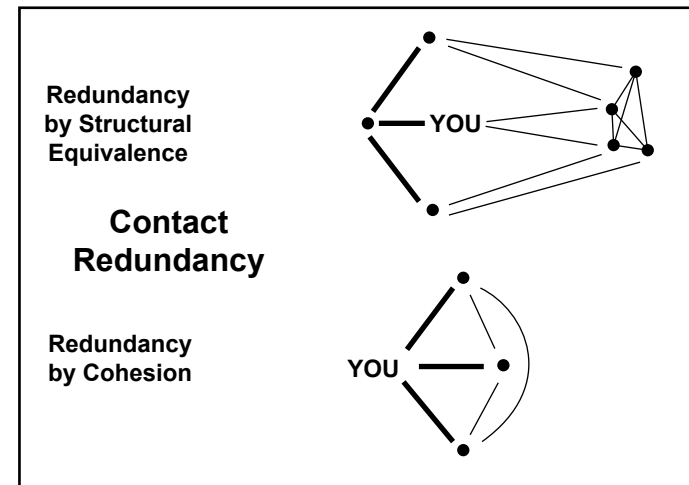

- A. They actually do not influence one another if they don't talk to one another.
- B. They are influenced by personal preferences.
- C. They are influenced by feeling loss if a peer moves ahead.
- D. They only seem to influence one another because they talk to the same people.

(Q291) How do closed networks create a fear of endorsing or doing something new? (Hint: Why might network brokers be less subject to this fear?)

- A. Reverse cause; people who are afraid tend to build closed networks.
- B. Closure makes interpersonal comparisons more obvious.
- C. Endorsing or doing something new always involves a risk.
- D. If you continue do to familiar things, you have the comfort of knowing where you stand relative to others.



A Problem: the Agency Question (or Reputation Cost)

Spillover evidence on information access versus process by-product
Network mechanism for brokerage is local and personal, emphasizing agency

A Solution: Psychophysics in Social Context

Social networks define peers, and by so doing, predictably distort preferences
Bent preferences recover a classic concept yet preserve discipline foundations

Evidence: Network Fear & Brokers Less Subject to It

Loss is amplified to painful and quick — in distinct, closed networks
(structural equivalence, e.g., highway experiment, finalists in competition, or cohesion, e.g., members of elite team)

NASCAR crashes (situational loss aversion)

Buying a New Car (loss emotion is sharp, but short-lived)

Brokers - Less Afraid of Cooperation with Strangers

Brokers - Less Afraid to Show Emotion

Brokers - Operating in a Broader Time Horizon

Network Fear — The more closed and distinct a person's network, the more intense the feelings of loss as peers overtake ego, fading as ego falls further behind.

"Every time a friend succeeds, a little something in me dies." Gore Vidal, 1973 *London Times*

Networks create a pressure on ego to act by defining the frame of reference through which ego evaluates alternative actions. That pressure is disproportionately about fear of falling behind peers.

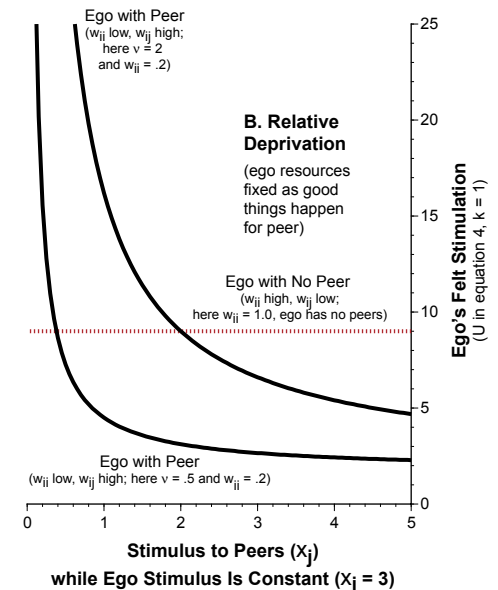

- (1) Loss severity is illustrated by the bold line in the above graph (from page 10) decreasing sharply before it crosses the dashed line, and is defined by the relative rates at which ego is affected by increases in her resources versus those of a peer.
- (2) Fading severity is illustrated by the solid lines (in the graph) changing more slowly after ego is surpassed by her peers. The point is defined by the decreasing rate of change in ego's felt resources with continued peer success (decreasing second derivative).
- (3) Network fear is weaker for brokers because their open networks are more ambiguous in defining peers. In other words, the dashed line in the above graph describes network brokers.

More distinct and closed networks define higher network weights, w_{ij} , which makes ego i's feelings more defined in relation to colleague j. It is well known that loss on average is more disturbing than gain. The key point here is that feelings of loss are amplified by the social situation in which loss is experienced. The same person subject to the same loss in different social situations can have different feelings of loss.

Network Fear Hypothesis Illustrated

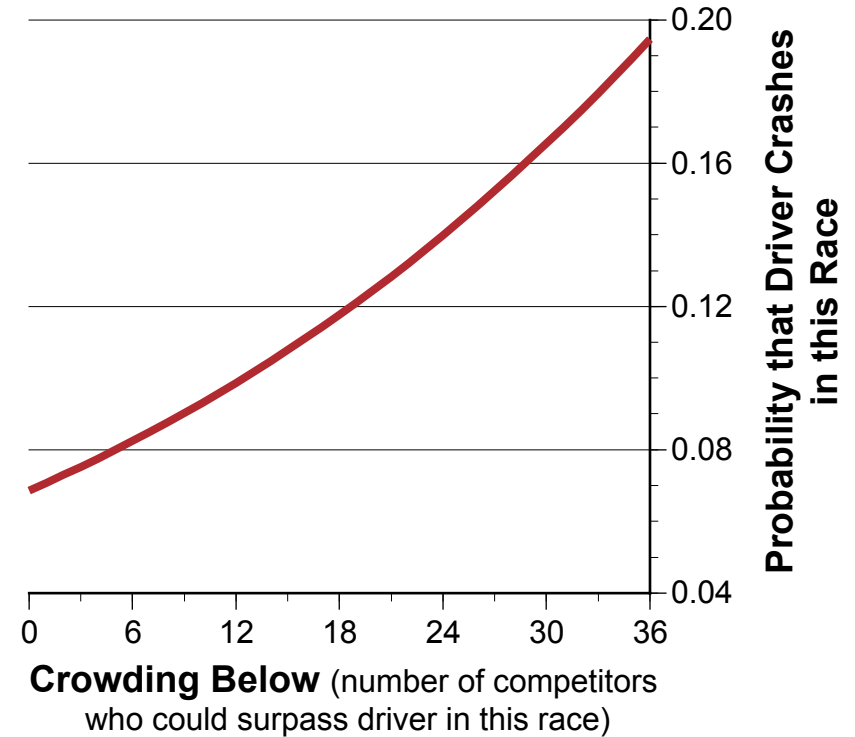
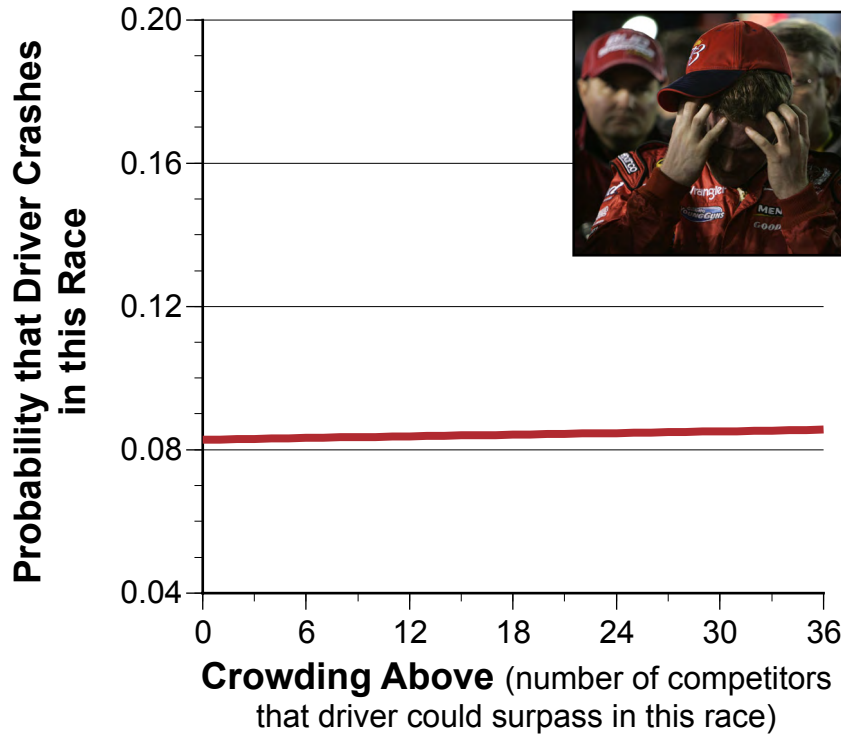

$$P(\text{crash in this race}) = \frac{1}{1 + e^{-f}} \quad f = -3.493 + .033R + .012N + .0005CA + .033CB$$

(12.5) (3.3) (0.1) (6.1)

Logit is estimated across 18,617 NASCAR driver-race observations between 1990 and 2003. Graph probabilities are computed for mean values of the three predictors not in graph. Data are courtesy of Matthew Bothner, from Bothner, Kang, and Stuart (2007, *Administrative Science Quarterly*, see page 226 for effect magnitudes with extensive controls).

where unadjusted logit test statistics are in parentheses, R is driver's rank at start of this race (mean 20.57, range 1-44), N is this race's sequence in year (mean 16.77, range 1-36), CA is crowding above going into this race (mean 6.36, range 0-42), and CB is crowding below (mean 6.36, range 0-42).



Effect on Ego's Probability of Car Purchase (multiplier)

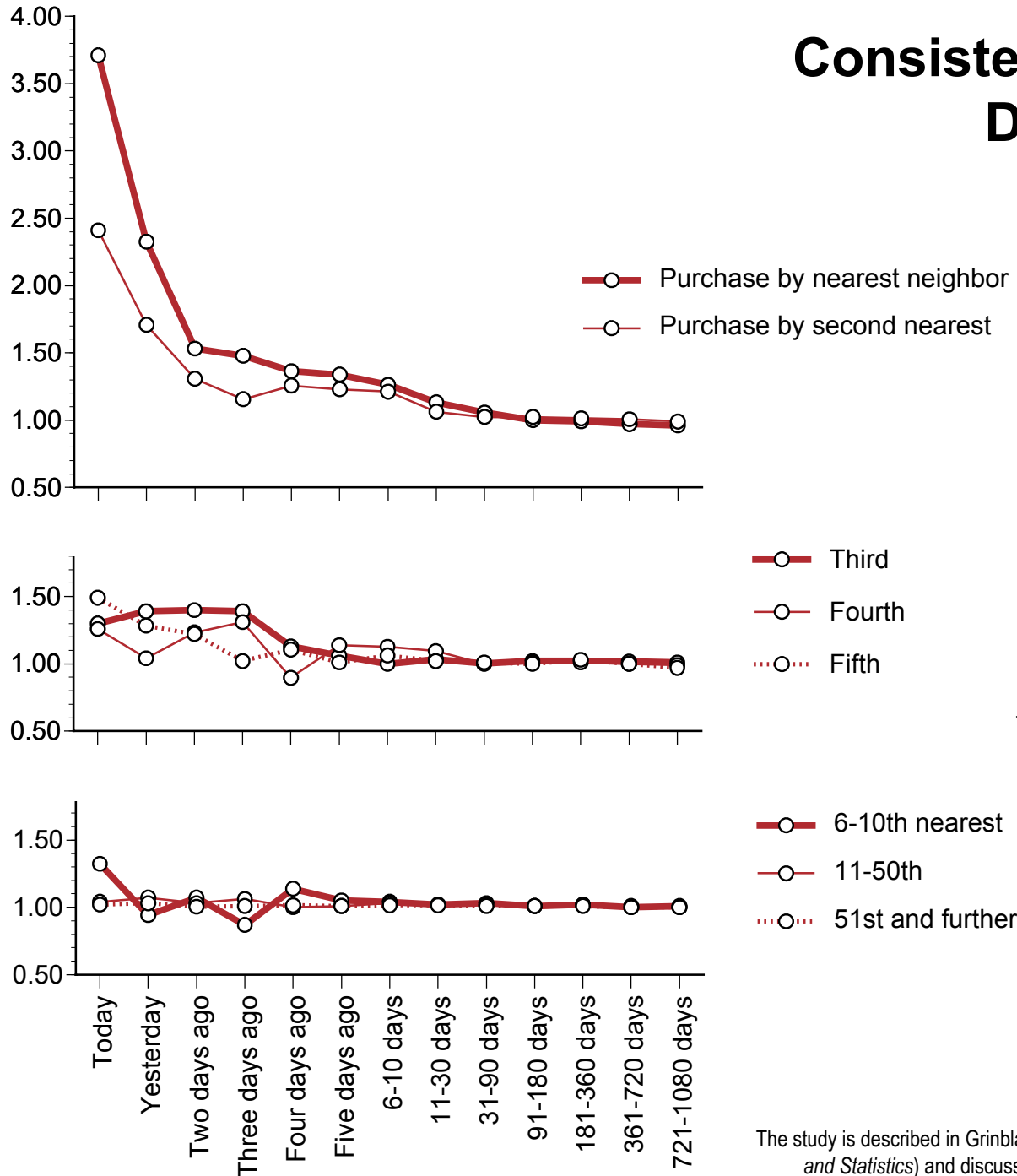

Consistent with the Model, Deprivation Effects Decay Quickly with Time and Distance

The graphs show multiplier effects on the odds that ego will purchase a car this year given neighbor purchases. Holding other factors constant, for example, the odds of ego buying a car this year are 3.71 times higher if ego's nearest neighbor bought a car today.

The multipliers are exponentiated logit coefficients computed across more than two million observations of people from 1999 through 2001 (3 annual observations per person) in the two most densely populated regions in Finland. To highlight effect decay with time and distance, I use multipliers instead of logit coefficients, and multipliers are smoothed across their prior and subsequent time intervals (except the first and last multipliers, which describe only the first and last time intervals).

The study is described in Grinblatt, Keloharju, and Ikäheimo (2008, *Review of Economics and Statistics*) and discussed on pages 37-38, 240-241 of *Neighbor Networks*. The authors generously provided their logit coefficients from which I computed multipliers for this slide. Appendix IV contains more detail on these graphs (also note in Appendix I the greater significance of first peer relative to additional peers).

Time When Neighbor(s) Made Car Purchase

People in Closed Networks Are Less Likely to Cooperate with Outsiders

The more closed the inside, the more safe & comfortable the inside, and the more risky the outside is perceived to be, Especially for people who have been successful with a closed network.

A Behavioral Measure of Cooperation

“Like you, the other player is CEO of a Chinese firm, and a citizen of China.”

Your Move:	Move by Other Player	
	Cooperate	Defect
Cooperate	250, 250	50, 400
Defect	400, 50	100, 100

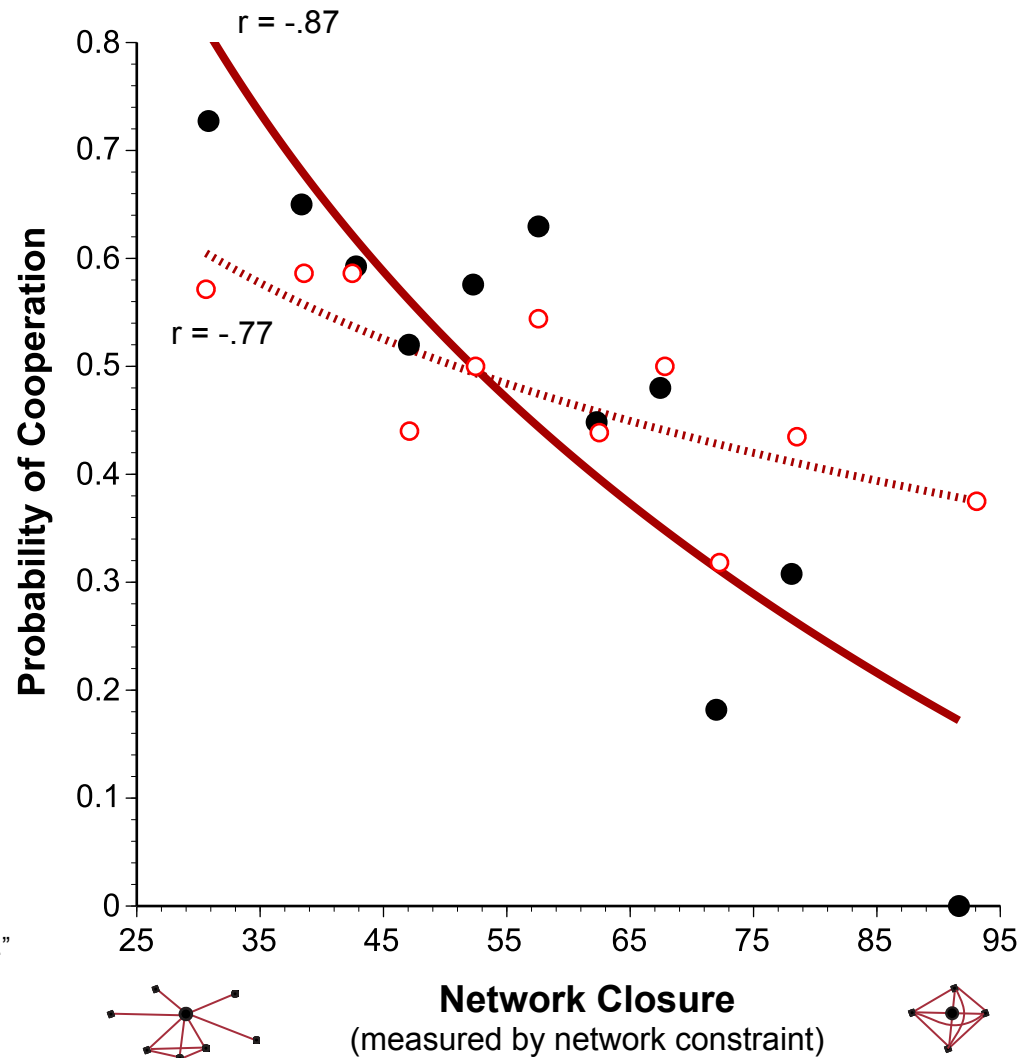

Observations are averages for 5-point intervals on X, with tails of X truncated for infrequency. Correlations are computed from data in the graph. Hollow dots are averages for all observations. Solid dots are averages for more successful entrepreneurs (distinguished by above median profit last year).

Figure 1 in Burt, Opper & Holm, "Cooperation beyond the network" (2022, *Org Science*)

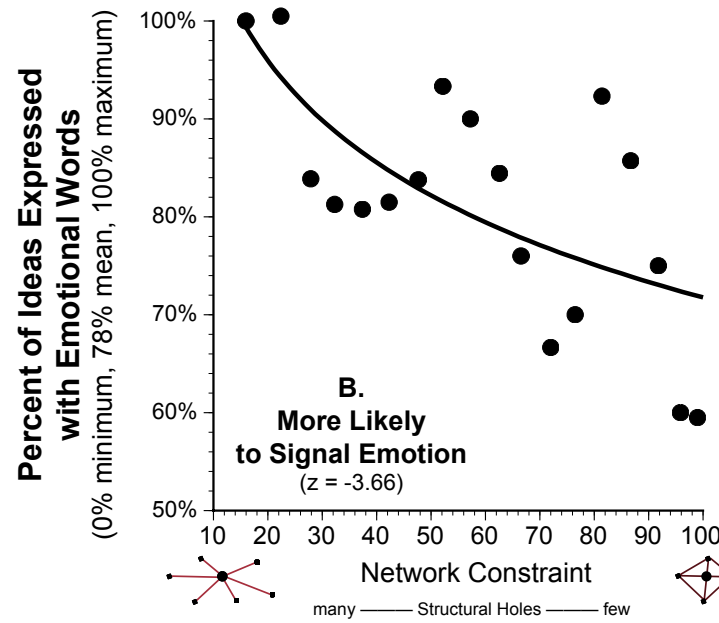
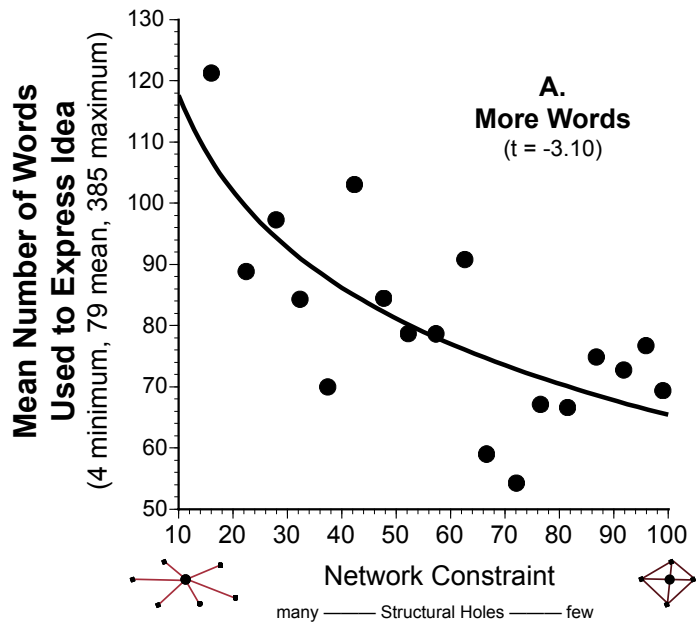

Brokers Are More Likely to Express Emotion when Pitching an Idea

(Scores are averaged within 5-point intervals of network constraint. Logit z-score tests for association with network constraint are reported in parentheses)

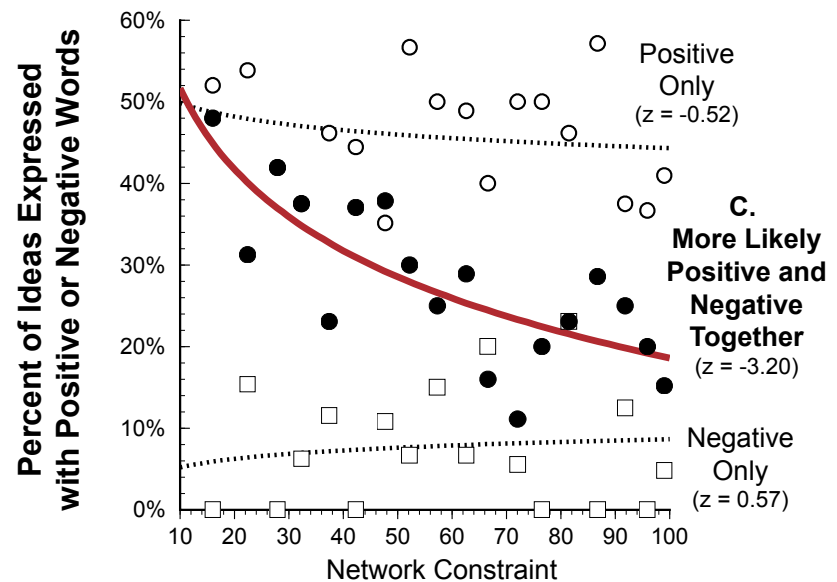
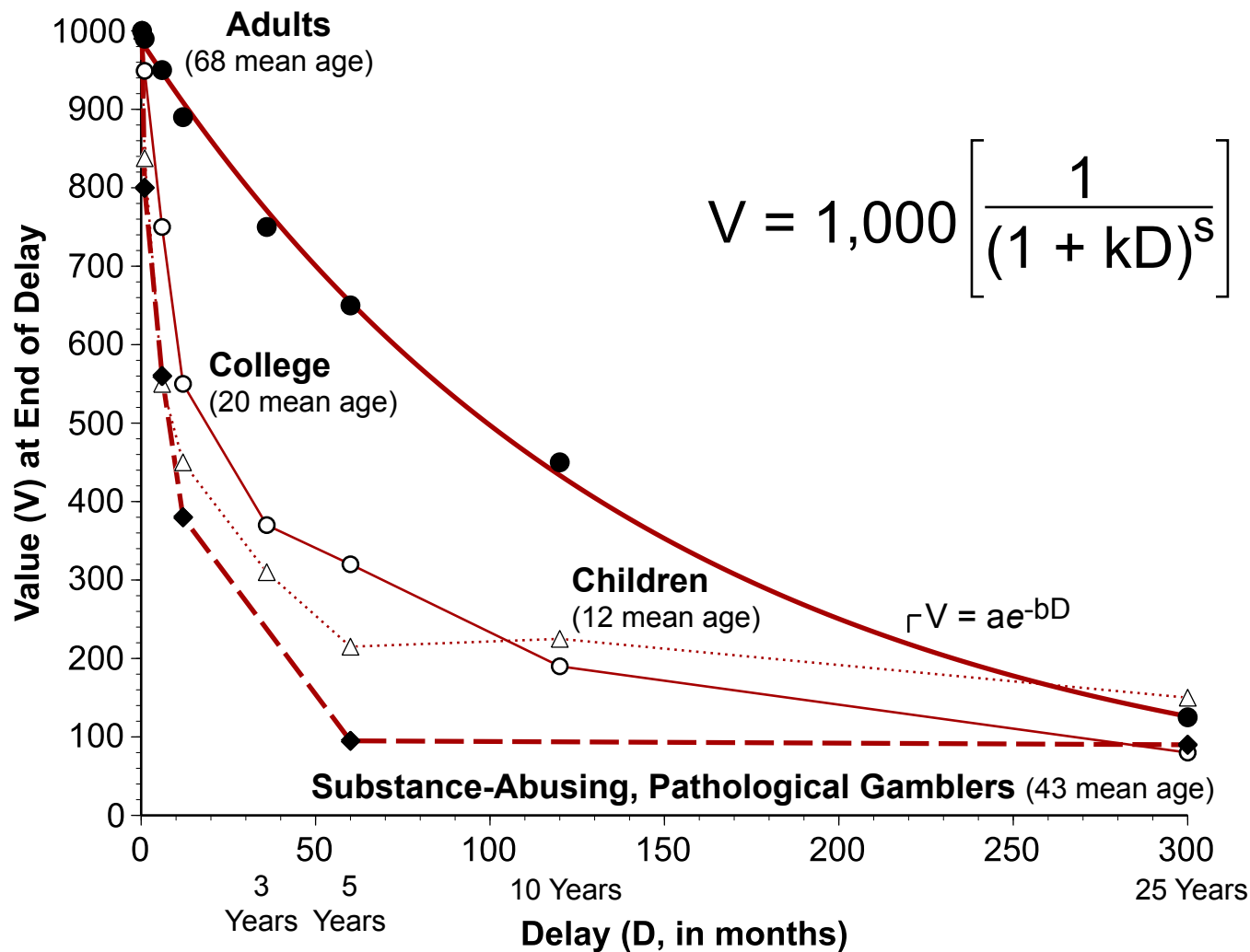

Figure 8.7 in *Neighbor Networks*. See Appendix V for detail on emotions within sentences. Also see HBR pieces by Goleman (1998) on the "emotional intelligence" of leaders, Hallowell (1999) on the "human moment" at work, and Casciaro and Lobo (2005) on "Competent jerks and lovable fools."



Brokers Are Less Subject to Temporal Myopia

Temporal myopia, also known as:

- temporal discounting
- present bias
- telescoping
- time perspective
- time preference
- impatience
- short-termism

Value, V , of a thousand-dollar payment delayed for D months.
 Bold solid line for adults illustrates exponential discount function.
 Others are better described by the hyperbolic.

Figure 1 in Burt, "Social network and temporal discounting" (2017, *Network Science*)

What would you do in this situation?

You have a bond that will be worth \$10,000 when it matures. Payment on the bond is guaranteed.

You would prefer to have the cash today. A person offers to buy your bond. They'll give you cash today for an amount less than the bond at maturity, then they will wait to collect the future bond payment. It is in your interest to get as much as possible today. It is in the buyer's interest to pay as little as possible. The longer the delay to maturity, the less the buyer will pay because they have to wait longer for their payment. The final exchange will occur somewhere between your interests and the buyer's.

If the bond matures in 10 years, and you want cash today, use the slider below to indicate the minimum amount you would accept today in exchange for the bond. (Click on the arrow and drag it to the right for more cash today or left for less cash. Click the "ok" button when you've set the amount)

\$5,000



ok

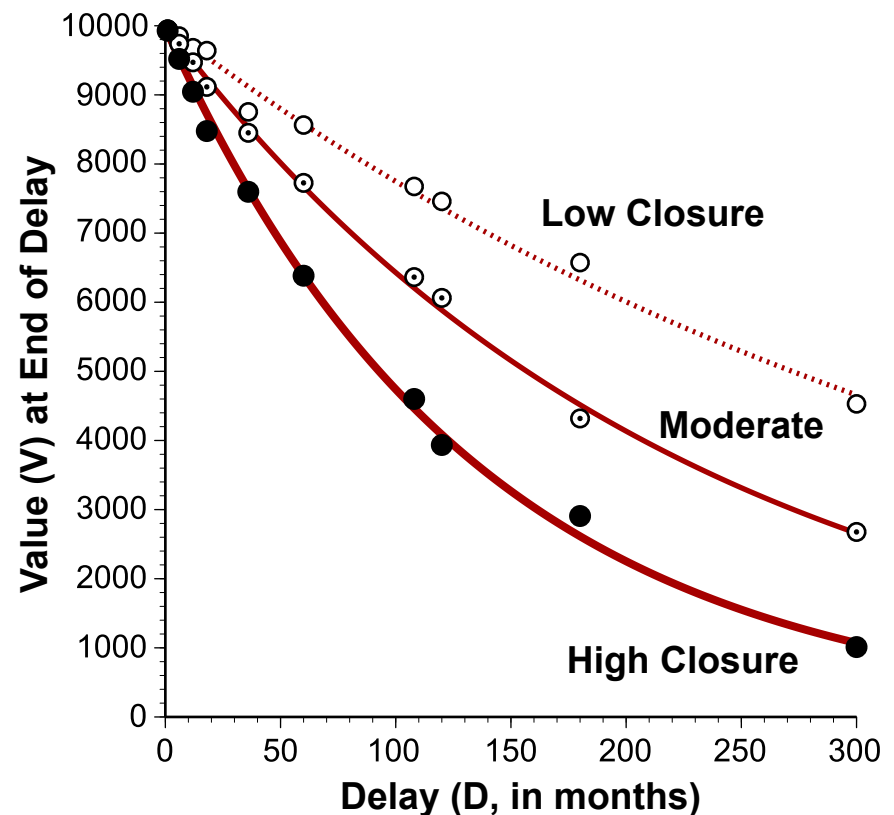

EMBA Discount Functions in More and Less Closed Networks

Fifty volunteer EMBA students were presented with the bond evaluation problem to the left. Median evaluations are plotted to the right for three categories of the students (low closure [dashed line], middle closure [thin line], and high closure [bold line]) evaluating bond value at ten time delays (1, 6, 12, 18, 36, 60, 108, 120, 180, and 300 months). The displayed regression lines through the plotted data fit the data well ($R^2 \geq .99$).

Figure 8 in Burt, "Social network and temporal discounting" (2017, *Network Science*)

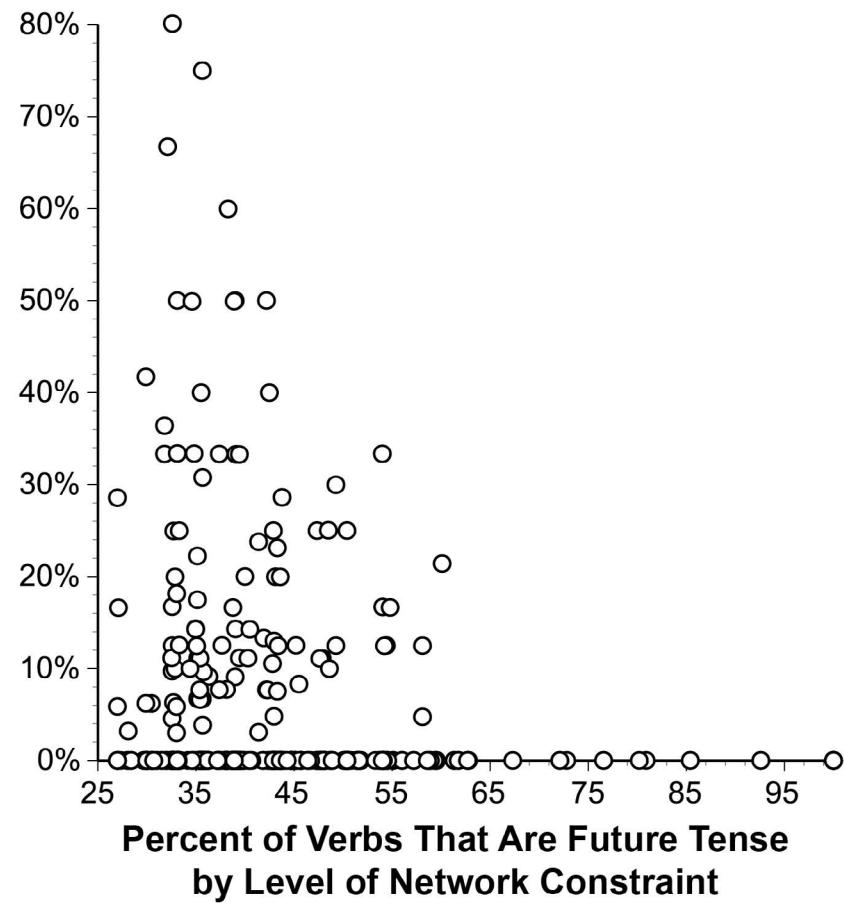
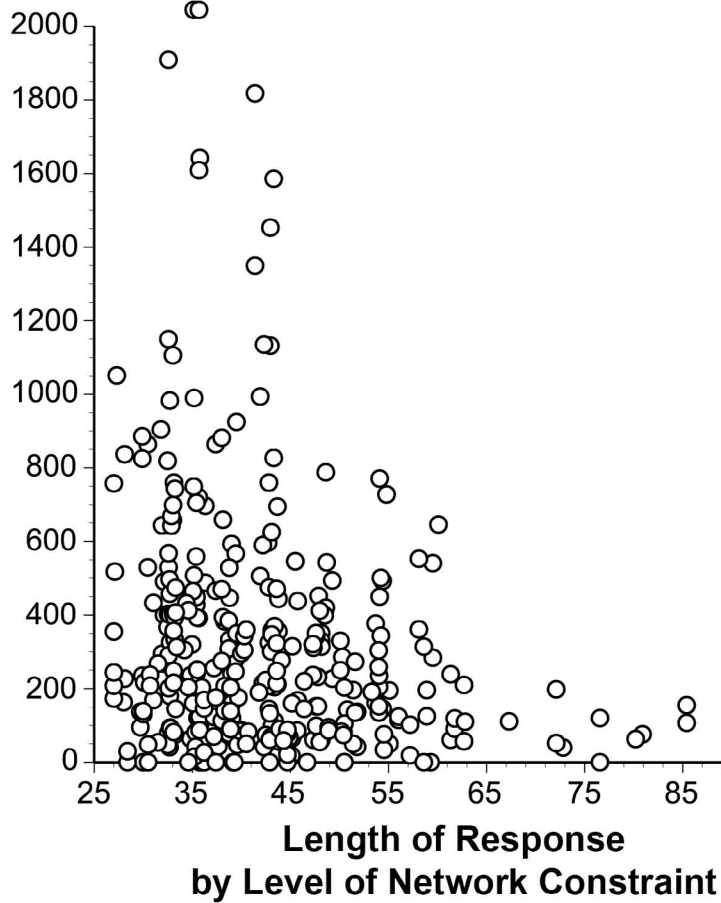

The Future Disappears in Closed Networks

These results describe language used by the 351 managers in the financial services organization. Horizontal axes in the graphs distinguish managers in closed networks, more constraint indicating more closure. Symbols in the graph indicate individual managers. Vertical axis to the left is a count of the characters in a manager's text response. Vertical axis to the right is the proportion of verbs in a manager's response that are future tense.

Professor Sameer Srivastava (Berkeley) offers tantalizing evidence consistent with the inference (personal communication, October 30, 2016). Using email messages among employees in a high-tech company to measure monthly a person's network constraint and the proportion of verbs that are future tense in the person's messages, Professor Srivastava finds the expected within-person covariation: In the month after an employee's network becomes more constrained, his or her use of future-tense verbs decreases, or conversely, in the month after an employee's network becomes less constrained, his or her use of future-tense verbs increases.

Figure 7 in Burt, "Social network and temporal discounting" (2017, *Network Science*)

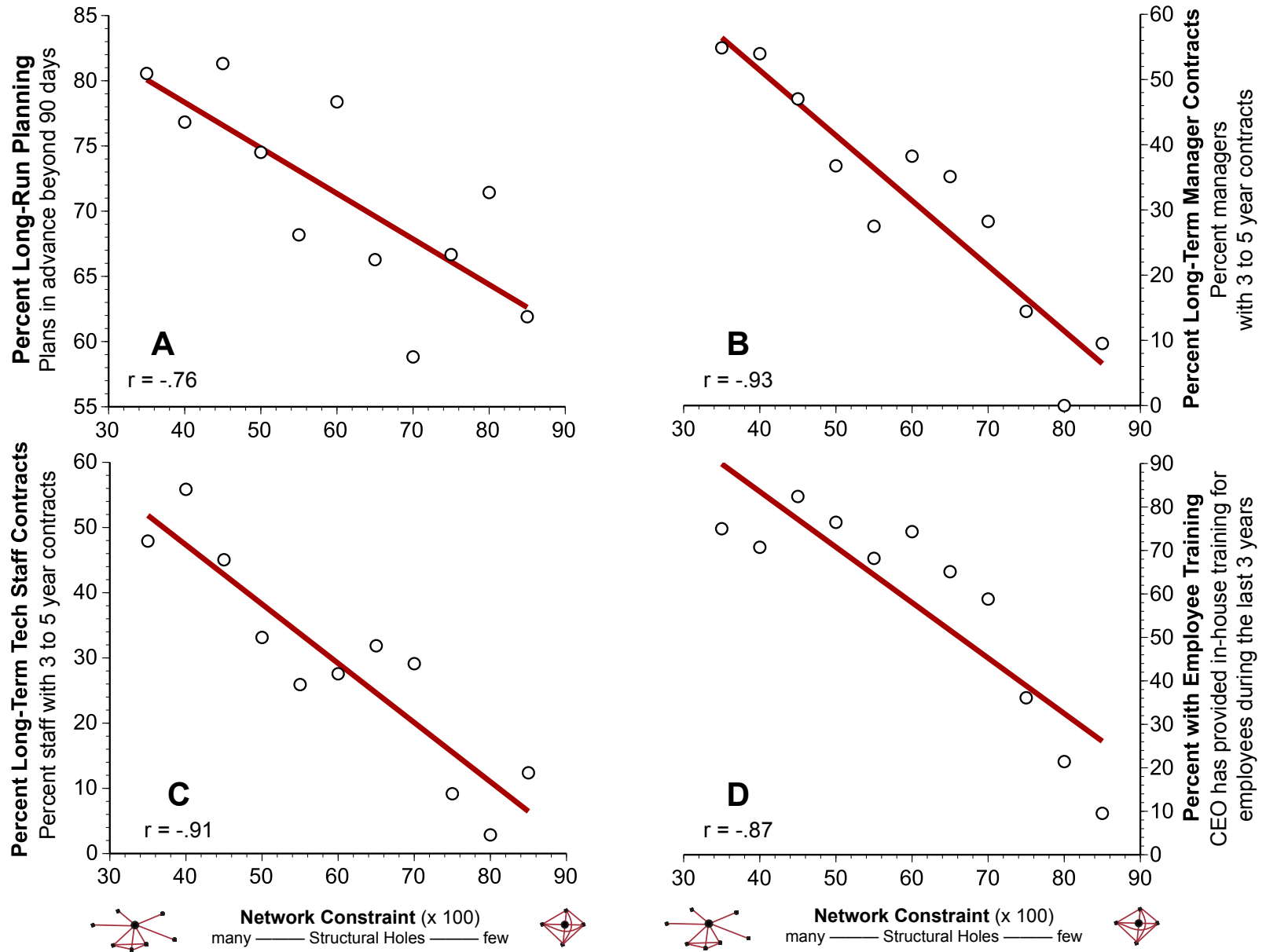

Planning Horizons Are Shorter for CEOs in More Closed Networks

Data are averaged within five-point intervals of network constraint, with extremes truncated for lack of observations.

Figure 2 in Opper and Burt, "Social network and temporal myopia" (2019, *Academy of Management Journal*)



(Q292) Building bridges across structural holes can be tense because of differences in beliefs and behaviors, so it is wise to use unemotional language. **True or False?**

A. True.

B. False.

(Q293) Building bridges across structural holes can be tense because of differences in beliefs and behaviors, so network brokers tend to focus on getting things done in the short-term rather than planning for the long-term. **True or False?**

A. True.

B. False.

(Q294) Managers in closed networks are prone to temporal myopia. **True or False?**

A. True.

B. False.

(Q295) Falling behind peers generates a feeling of failure that never fades. **True or False?**

A. True.

B. False.

To Re-Cap the Session:

A Problem: the Agency Question

Spillover evidence on information access versus process by-product
Network mechanism for brokerage is local and personal, emphasizing agency

A Solution: Psychophysics in Social Context

Social networks define peers, and by so doing, predictably distort preferences
Bent preferences recover a classic concept yet preserve discipline foundations

Evidence: Network Fear & Brokers Less Subject to It

Loss is amplified to painful and quick — in distinct, closed networks
(structural equivalence, e.g., highway experiment, finalists in competition, or cohesion, e.g., members of elite team)

NASCAR crashes (situational loss aversion)
Buying a New Car (loss emotion is sharp, but short-lived)
Brokers - Less Afraid of Cooperation with Strangers
Brokers - Less Afraid to Show Emotion
Brokers - Operating in a Broader Time Horizon

Fear Manifest & Managed

**Paul Potts at “Britain’s Got Talent”
in Cardiff, Wales, June 9, 2007**

(age 37, manages mobile phone shop
seven miles from birthplace)





Appendix Materials

Appendix I: Closure Stability Effects Spill Over between Neighbor Networks

	Stability Effect Closure among Direct Contacts	Stability Effect Closure among Indirect Contacts
Brokerage Effects		
Brokerage association with product-launch employee compensation (Table 3.1)	2.7	1.0
Brokerage association with supply-chain manager salary (Table 3.2)	3.4	1.6
Brokerage association with supply-chain manager annual evaluation (Table 3.2)	2.9	-.7
Brokerage association with quality of supply-chain manager best idea (Table 3.2)	4.2	.9
Brokerage association with HR compensation (Table 4.1)	4.4	.2
Brokerage association with banker compensation (Table 4.2)	3.4	1.5
Brokerage association with analyst election to All-America Research Team (Table 4.3)	3.2	-.2
Closure Effects		
Closure association with stable analyst reputation (Table 6.2)	12.0	8.3
Closure association with stable banker reputation (Table 6.2)	11.5	8.0
Closure association with decay in analyst relationships (Table 6.4)	-9.7	-4.0
Closure association with decay in banker relationships (Table 6.4)	-5.4	-3.1
Choice status association with banker compensation	4.9	3.5
Choice status association with analyst election to All-America Research Team	2.8	3.1

Note — These are test statistics for the association in the row with control variables held constant from the indicated tables. The status predictions in the bottom two rows are made with the same variables as the brokerage predictions in Table 4.2, Model C for the bankers, and in Table 4.3, Model C, for the analysts, except that the two brokerage variables in each prediction are replaced by corresponding status variables.

Table 6.5 in Neighbor Networks.

Appendix II: Detail on Relative Advantage and Relative Deprivation (this graph is advantage)

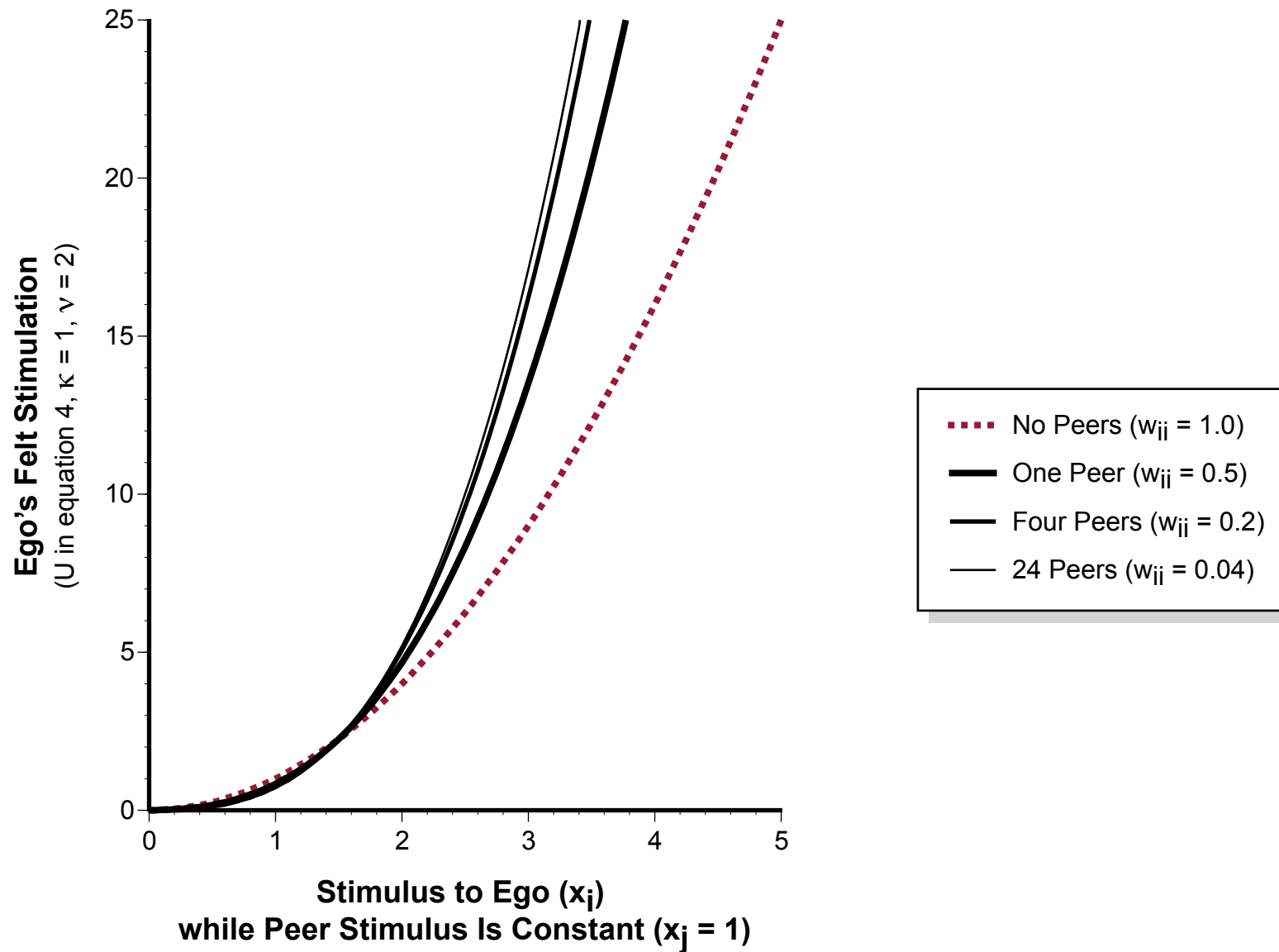

Detail on Relative Advantage and Relative Deprivation (this graph is deprivation)

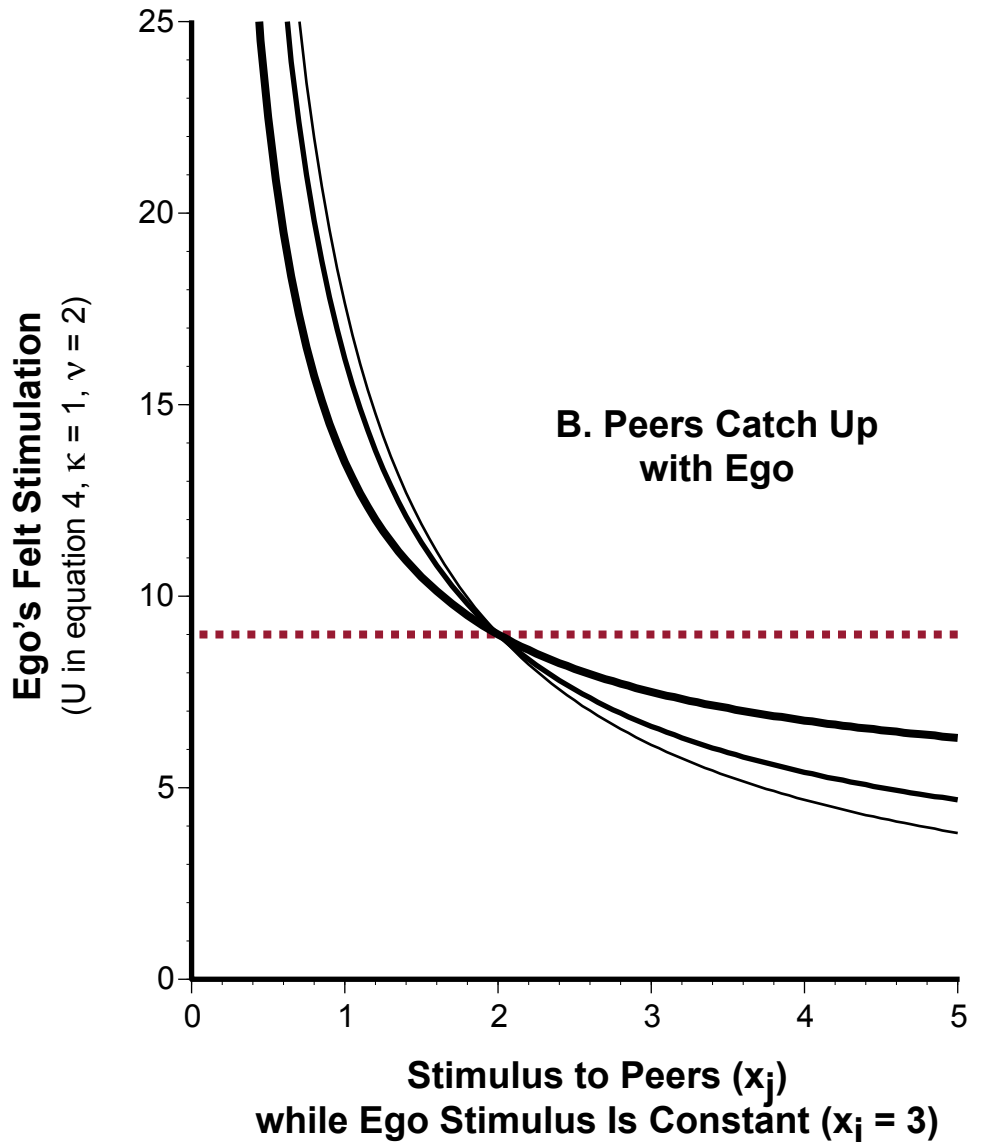
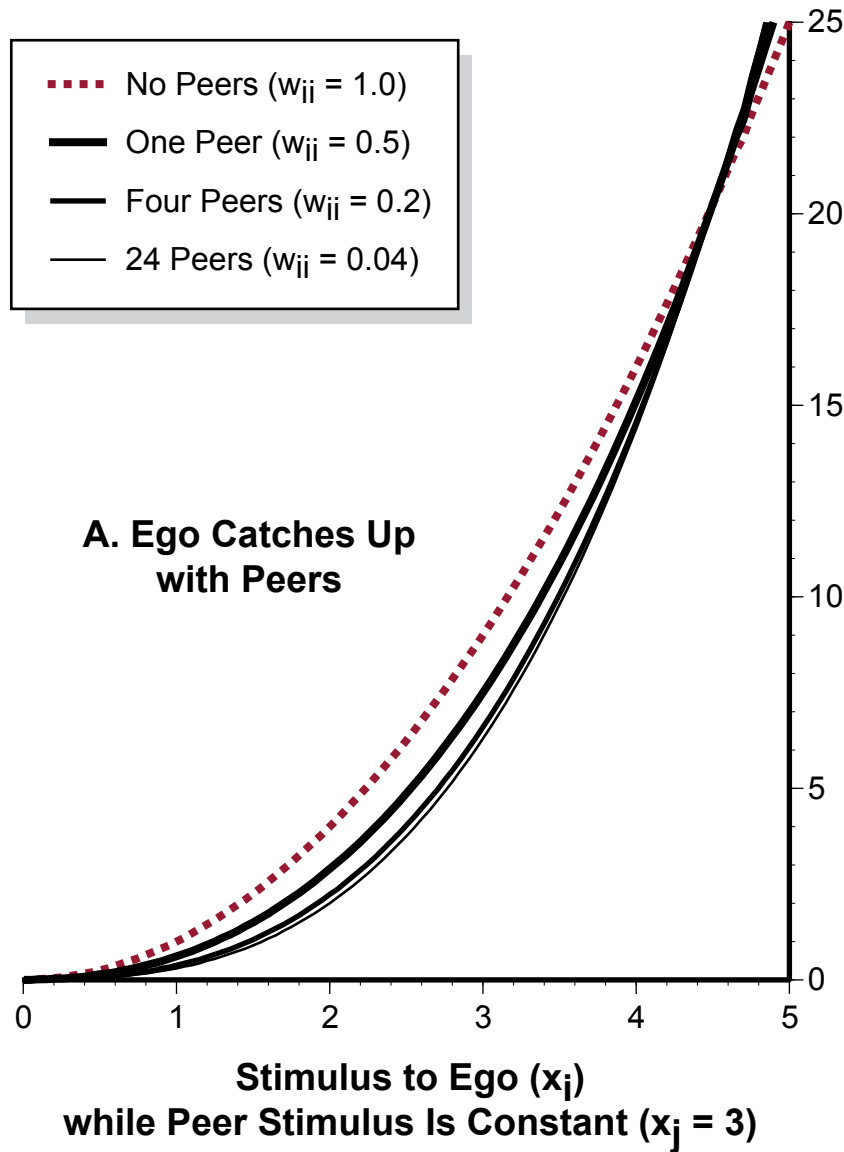

Figure 8.3 in *Neighbor Networks*

Detail on Relative Advantage and Relative Deprivation (classic Illustration from *The American Soldier*)

**People with the Better Chances of Promotion (educated air corpsmen)
are more Negative about Promotion.**

Opinion of Promotion Chances	Military Police, High School or College (n = 241)	Military Police with Less Education (n = 165)	Air Corps, High School or College (n = 152)	Air Corps with Less Education (n = 70)	Loglinear Z-Score Opinion Link with	
					Education	Air Corps
Positive	27%	58%	19%	30%	-5.93	-4.32
Neutral	53%	34%	47%	49%	1.43	-0.19
Negative	20%	8%	34%	21%	3.98	3.87
Percent at Higher Rank	34%	17%	55%	47%	—	—

Note — These are *American Soldier* sample noncommissioned officers in the two services during 1944 who have been in the Army for one to two years answering the question, “Do you think a soldier with ability has a good chance for promotion in the Army?” Column percentages and log-linear z-score test statistics are given. Positive response is “A very good chance.” Negative responses are “Not much of a chance” or “No chance at all.” Neutral responses are “A fairly good chance” or “Undecided” (see footnote 5 on page 236 of *Neighbor Networks* for test statistics and explanation of combined responses). High education is high school graduate or some college. Low education is less than high school graduate.

Appendix III. Relative Income Hypothesis in Economics

In the year that Stouffer in the Harvard Sociology Department published the first volumes of *The American Soldier*, which became the touchstone for the concept of relative deprivation in sociology, an assistant professor in the Harvard Economics Department published *Income, Saving, and the Theory of Consumer Behavior* (Duesenberry, 1949), which became a touchstone for the relative income hypothesis in economics. Another key work was in press, appearing a year later in Harvard's *Quarterly Journal of Economics*, the independent work of a graduate student at Princeton (Leibenstein, 1950). To my outsider sociologist eyes, Duesenberry (1949) and Leibenstein (1950) were milestone developments in economics corresponding to the concepts of social pressure, social comparison, reference groups, and relative deprivation emerging at the same time in sociology and psychology.

The work in economics did not receive the welcome enjoyed by corresponding work in sociology and psychology. Duesenberry (1949) and Leibenstein (1950) stood for years a neglected outpost, scarecrow warning to young economists. The relative income hypothesis is based on an assumption that ego's consumption — how she spends her resources — is affected by the usual factors of market price and ego's income, plus factors defined by the way other people spend their resources. People want what they see other people want (or, to use Duesenberry's, 1949:29, term, what other people “demonstrate” they want). The assumed interdependence contradicted the neoclassical assumption widely used in mid-century economics that people make their evaluations independently. In particular, the absolute income hypothesis proposed by Keynes said that consumption increased as a proportion of ego's income, and the permanent income hypothesis proposed by Friedman said that consumption increased as a proportion of ego's long-run expected income. The absolute and permanent income hypotheses were consistent with the reigning neoclassical economics and prospered accordingly (Mason, 2000). For example, citations to the book in which Friedman (1957) proposed the permanent income hypothesis were high from the outset. The Web of Science shows that the book was cited in 21.3 articles per year through 1969, 32.8 per year from 1970 through 1989, and 30.4 per year after 1989. In contrast, the Web of Science shows one citation to Duesenberry (1949) in the five years after it was published, an average of 2.7 citations per year for the first decade after the book was published, then after 50 years, when most mid-century work had been forgotten, Duesenberry (1949) receives a healthy average of 18.3 citations per year. Social diffusion is more obvious in the use of Leibenstein's article. Well-known today, the article was cited only three times in its first decade, and articles citing it during the first 20 years after its publication were themselves rarely cited (from 1951 through 1971, the ten articles citing Leibenstein, 1950, were cited an average of 3.7 times over their lifetime — through 2008). Duesenberry (1949) showed the same pattern of its few early citations coming from peripheral articles that were themselves rarely cited. With the exception of a Modigliani article on the life-cycle-income alternative to the relative income hypothesis, articles citing Duesenberry (1949) in the first 20 years after the book's publication were themselves rarely cited. As Frank (1985:146) described the situation at a time when social comparison was not yet fashionable in economics, “Duesenberry's relative income hypothesis has been relegated to a historical footnote in most modern economics textbooks.” And as Frank (2005) continued to bemoan the lack of attention to Duesenberry 20 years later: “This is surprising because his theory of consumer behavior clearly outperforms the alternative theories that displaced it in the 1950s — a striking reversal of the usual pattern in which theories are displaced by alternatives

From "Corresponding Developments in Economics" section of Appendix G in *Neighbor Networks*. References to Chapter 8 here refer to Chapter 8 in *Neighbor Networks*, and literature references are given in the book.

that better explain the evidence. His disappearance from modern economics textbooks is an intriguing cautionary tale in the sociology of knowledge.”

Implications of the relative income hypothesis are illustrated in Leibenstein’s (1950) analysis of what he described as the “nonfunctional” market demand that can result from social comparison. (Sanders, 2008, provides useful didactic introduction to the relative income hypothesis.) Leibenstein’s bandwagon effect refers to ego’s demand for a product increasing because other people are buying it (cf. Duesenberry’s, 1949, demonstration effects). Leibenstein’s taboo effect refers to ego not wanting a product because too few other people are buying it. His snob and Veblen effects refer to ego not wanting a product because too many other people have it or can afford it. The neoclassical prediction is that a decrease in price triggers an increase in demand along the market demand curve. If there is a bandwagon effect, however, increased demand triggers new demand from people entering the market, people who were not interested before but are now interested because other people are buying the product. Decreasing price therefore has two effects on demand: it increases demand from people in the market, and it increases demand from new people entering the market (Leibenstein, 1950:195). Where a bandwagon effect is operating, price decrease triggers a disproportionately large increase in demand (because new buyers are attracted by the larger number of people consuming at the lower price). Where a snob effect is operating, in contrast, price decrease triggers a disproportionately small increase in demand, and a Veblen effect can trigger decreased demand, because potential buyers are repulsed by the larger number of people consuming at the lower price (Leibenstein, 1950:201-202).

Note the lack of attention to the process of social comparison. Social comparison is assumed. The analytical focus is on aggregate market behavior. If people engage in social comparison, then there are predictable implications for the association between market price and demand; changes in price can trigger disproportionately large or small changes in demand.

One implication of the analytical focus on aggregate market behavior is that the empirical evidence offered to justify attention to social comparison processes is at the market level, far from the interpersonal processes presumed responsible. For example, Duesenberry (1949) offers empirical support from income put aside as savings. The absolute and permanent income hypotheses predict savings in proportion to income, the higher ego’s income, the more that can be put aside in savings. The relative income hypothesis predicts that keeping up with the Joneses consumes a larger proportion of income for low-income people, leaving less for savings, so wealthier people are predicted to put a higher proportion of their income into savings, which is the observed pattern of savings (Duesenberry, 1949:chap. 3; Frank, 1985:144-149). Similarly, Easterlin (1974) is a popular citation for evidence legitimating the need for concepts of social comparison: happiness and income are correlated within countries but not across, implying that happiness is a response to relative income, not absolute income.

A second implication of the lack of attention to interpersonal processes is an indifference to criteria that distinguish the peers to whom ego compares herself. Liebenstein’s (1950) concepts of bandwagon, taboo, snob, and Veblen effects are defined with respect to all other consumers. Leibenstein (1950:190) acknowledges that ego’s demand could be affected by a subgroup of other people, but decided in the interest of simplicity to assume that ego’s demand is affected by everyone else (“Initially, therefore, we assume that A’s demand is a function of the units demanded by all others collectively” Leibenstein, 1950:191). That simplifying assumption about social comparison continues to be useful (e.g., Rayo and Becker, 2006: 236-237). Duesenberry

distinguishes individual peers, but leaves the distinction intuitive. He had a connectivity criterion in mind (consistent with the Festinger research he cites in justification of social comparison). He (1949:32) begins his formal model with ego comparing herself to people with whom she associates: ". . . the frequency and strength of impulses to increase expenditures for one individual depend entirely on the ratio of his expenditures to the expenditures of those with whom he associates." He (1949:48) is more explicit about connectivity when presenting empirical evidence: "Any particular consumer will be more influence by the consumption of people with whom he has social contacts than by that of people with whom he has only casual contacts." Duesenberry's (1949:32) formal expression for social comparison contains network weights and an ego to peer resource ratio: $C_i / (\sum_j \alpha_{ij} C_j)$, where C_i is ego i's consumption, ego i is not included in the summation across other people j, and α_{ij} is "the weight applied by the ith consumer to the expenditure of the jth." The α_{ij} weights define an aggregate peer to which ego i compares herself. The weights are left intuitive in the sense that they remain buried inside the ratio of ego to aggregate-peer consumption, and the ratio is used to analyze implications of social comparison. This is not a flaw in the analysis. There was no authoritative evidence available at the time defining network weights, and a specific definition of the weights was not essential to the economic analysis (cf. Bagwell and Bernheim, 1996:353, on Veblen effects defined with respect to a representative social contact, where representative is left to intuition). My point here is only that the network criteria distinguishing peers in these economic analyses are intuitive rather than concrete.

In sum, empirical research on the relative income hypothesis in economics described aggregate market implications of social comparison while corresponding work in psychology and sociology described on the process by which, and circumstances in which, social comparison occurred. This is the reason for my statement in Chapter 8 that the relative income hypothesis and its component effects in economics had a great deal to say about population implications of social comparison, but little to say about the situations in which social comparison was likely so I drew little from that work for Chapter 8.*

The disconnect between economics and social psychology on the topic of social comparison is an opportunity. It is yet another place for a productive micro-macro bridge between the two disciplines (for broader discussion, see Coleman, 1990: Chap. 1). Social psychology is articulate about the mechanism by which interpersonal influence occurs, debating the relative merits of connected people socializing one another into a shared opinion versus structurally equivalent people competing with one another to be attractive to their shared constituency. Economic theory is articulate about macro hypotheses implied by people acting under specified constraints. Given people guided by bent preferences, what are the macro implications for demand, supply, and price? The social psychology of bent preferences narrows the variety of circumstances in which social comparison occurs, which can enhance the power of empirical research testing the macro hypotheses. For example, as discussed in Chapter 8, Frank (1985) shows that wage schedules are flatter than predicted for competitive labor markets so that people can avoid the pain of relative deprivation. However, wage schedules are predicted to be especially flat within groups of people made especially sensitive by structural equivalence to relative deprivation — as in a high-performance team.

*I missed more recent empirical work emerging in Europe. Haushofer, Reisinger, and Shapiro (2019 working paper) report modest relative deprivation effects on ego's life satisfaction in Kenya when mean village income increases relative to ego's, and Ferrer-i-Carbonell (2005 *J. Public Economics*) reports dissatisfaction from having an income lower than average for your education category, age category, and region in Germany.

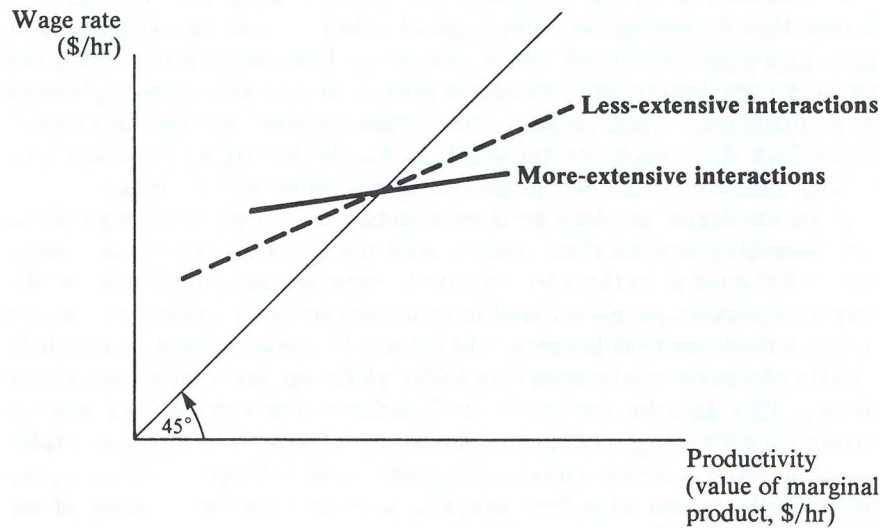

Cornell Organic Chemists and Biochemists, 1980

Ranking in Department	Estimated Salary	Indirect Cost Income per Faculty
Top	58,025	245,000
Median	53,383	92,994
Bottom	40,618	8,575

Status-Compensation Trade-Off in Managing Teams

An implication for organizations is that some people are willing to work for low pay and little opportunity for promotion to avoid the pain of relative deprivation. In the above graph, the vertical axis is pay (e.g., compensation dollars per month an individual receives) and the horizontal axis is performance (dollars per month the individual produces). Plot pay versus performance for employees doing the same kind of work in an organization. If employees were paid for what they produced, a regression line through the data would have a slope of one; the highest paid employee would be proportionally the highest performing employee, and so on. Observed slopes are typically less than one, as illustrated above. Frank (1985: Chaps. 3-5) attributes this to people exchanging compensation for status (cf., Blau's, 1955, *Dynamics of Bureaucracy*). In exchange for deference from colleagues, high performers are willing to receive less pay than would be appropriate to compensate their high performance. Low performers are willing to give deference to colleagues in return for receiving higher pay than would be appropriate for their low performance. Frank adumbrates the intrepid broker hypothesis when he links flattened pay schedules to dense networks (1984: 552; 1985: 51): "In firms in which co-workers perform their tasks independently of one another, one's rank among one's co-workers should matter less than it does in a firm in which interactions among co-workers are more extensive. . . . An important implication of the theory of markets for local status is that wage schedules will be flattest in those firms in which co-workers interact most intensively." The intrepid broker hypothesis says that people in closed networks are, relative to network brokers, motivated by fear of relative deprivation. One manifestation of that fear should be flattened pay schedules, with performance compensation extended beyond pay to include status symbols such as job titles, fringe benefits, and colleague deference (Frank, 1985: 91-94). In short, relative deprivation is key to the reputation costs that drive alignment within teams. If reputation in a closed network is responsible for the greater productivity of high-performance teams, and pay schedules are flatter in closed networks (where relative deprivation would otherwise be more severe), then high-performance teams should have flatter pay schedules.

Graph is Figure 3.4 in Frank (1985, *Choosing the Right Pond*), and table is from Tables 4, 6, and 7 in Frank (1984, *American Economic Review*). Text is from pages 239-240, 267 of *Neighbor Networks*.

Appendix IV: Detail on Grinblatt, Keloharju, and Ikäheimo (2008)

The multipliers illustrating relative deprivation effects on page 17 of this handout are based on the analysis reported in Grinblatt et al. (2008, *Review of Economics and Statistics*). The authors combined tax and auto registration data from 1999 through 2001 for every resident in the two most densely populated provinces in Finland to answer the following research question: How does ego react to neighbors coming home in newly purchased cars? The article is a good read if you are interested in social influence, but with respect to my use of the data, three details warrant mention beyond the text on page 17.

(1) The dependent variable is ego purchased a car this year. There are three observations for each resident in the population (1999, 2000, and 2001, excluding observations in years when ego was not a resident) for a total of 2,520,757 observations. If ego purchased a car this year, the dependent variable is 1 and the date of purchase is known. If ego did not purchase a car this year, the dependent variable is 0 and ego is assigned at random to a non-purchase date based on the population distribution of car purchases during the year (see "shadow purchase price," pp. 737-738 of the article). Given a date of purchase or non-purchase, neighbor purchases can be tallied for same day, day before, two days before, etc.).

(2) The detailed neighbor data provide a control for unobserved neighborhood variables. Given purchases by each of the 500 nearest neighbors, association with ego's purchase was noteworthy for neighbors 1-10 as an "inner-ring" and neighbors 11-50 as an "outer-ring." Outer ring purchases are subject to the same unobserved neighborhood variables as inner ring (such as the neighborhood is a good place to raise children, a local status symbol, supports a preferred political view, or has an identifiable tolerance, or lack thereof, for diversity). By holding outer-ring purchases constant, the unobserved neighborhood variables that could be creating correlation between inner-ring purchases and ego's purchase are held constant.

(3) The above graph — which is Figure 1A on p. 744 in the article — plots 135 time-distance coefficients for logit regressions predicting whether ego purchased a car in a given year as a function of the number of cars purchased by neighbors, where neighbors are distinguished by the days ago that they purchased a car and the distance they are removed from the individual. Ego's purchase-relevant characteristics are also held constant (Table 2 on p. 743 in the article contains adjustments for age, family, employment, gender, home owner, income, urban-rural, year). Neighbor purchases are distinguished by 15 time intervals.

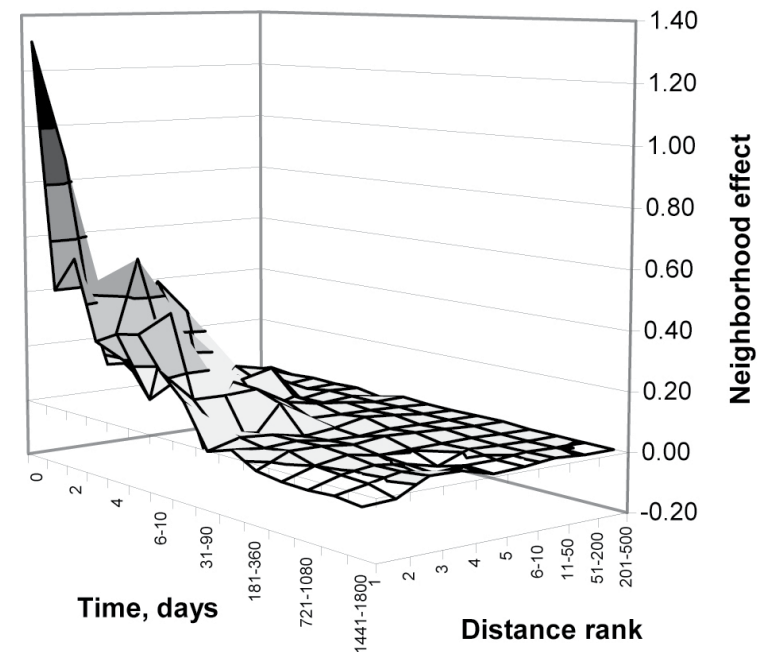

Nine distance intervals are distinguished: intervals denoted by numbers 1 through 5 represent the number of purchases of each of the five nearest neighbors (usually zero or one), whereas intervals 6–10, 11–50, 51–200, and 201–500 represent the collective number of purchases of 5–300 neighbors, depending on the interval.

If neighbor purchases had no effect on ego, the coefficients would all be equal. The surface plot would be flat. It clearly is not. Recent car purchases by near neighbors (the spike to the right in the graph) significantly increase the odds that ego will buy a car. The effect is strongest during the two days following neighbor purchases, with a weaker but still substantial effect for a week or two, and no effect thereafter (pp. 744-745 in the article). In fact, keeping-up-with-the-Joneses envy is put aside by the authors as a feasible interpretation of their observed neighbor effects because the effects are so transitory (p. 750): “it is difficult to explain how quickly the social influence of those nearest neighbors decays. Envy is a more persistent emotion.” On the contrary, the theoretical prediction illustrated on page 10 of this handout (Figure 8.3B in *Neighbor Networks*) is that the relative deprivation of falling behind the Joneses is a discomfort intense but short-lived. That prediction is consistent with the intense, short-lived neighbor effects reported by Grinblatt, Keloharju, and Ikaheimo.

The above surface plot is clearly not flat, but it is difficult to see detail in the plot because the three-dimensional data display has to be printed from a single two-dimensional view, and the logit coefficients bounce up and down between adjacent time intervals. The table below-left lists the logit coefficients just past the most influential time-distance variables (time down the rows, distance across the columns). The graph below-right shows how (in the above published graph) the line of logit coefficients for each distance category of neighbors varies across the time intervals. It is difficult to see effect decay with time and distance because the lines intermingle between adjacent time intervals. To highlight the effect-decay pattern, I present multipliers instead of logit coefficients on page 17 (to spread out the lines), separate into three graphs the effects of neighbors at increasing distance, and smooth effects on each line as a three-period running average.

	1	2	3	4	5	6-10	10+
Today	1.31	0.88	0.26	0.23	0.40	0.28	0.03
Yesterday	0.43	0.43	0.16	0.04	0.25	-0.06	0.05
Two days ago	0.55	0.16	0.53	0.21	0.20	0.07	0.02
Three days	0.28	0.19	0.28	0.27	0.02	-0.14	0.04
Four days	0.32	0.08	0.14	-0.11	0.10	0.13	0.08
Five days	0.33	0.39	-0.09	0.13	0.01	0.05	0.01
6-10 days	0.22	0.12	0.11	0.12	0.06	0.04	0.02
11-30 days	0.14	0.03	-0.03	0.09	0.02	0.02	0.02
30+ days	-0.01	0.01	0.02	0.00	0.00	0.01	0.01

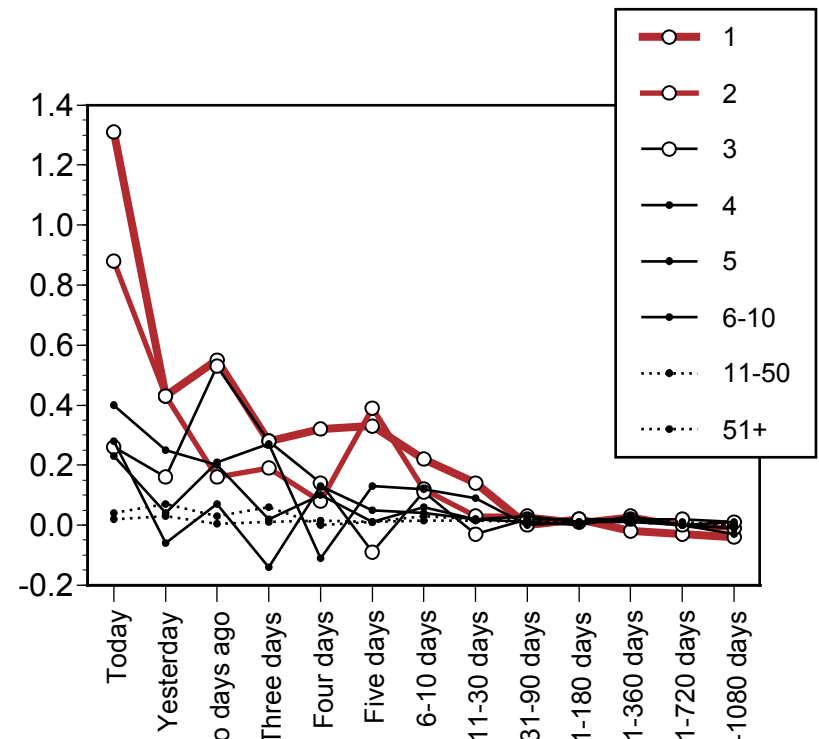

Appendix V: Detail on Emotion within Sentences

Using the data on page 19 of supply-chain managers pitching ideas for improving the value of the supply-chain organization, the graph below shows the tendency for managers to use positive and negative words within sentences. Network brokers are no different from closed-network managers in their use of positive words, or negative words, or positive words along with negative words (lines below are all flat across constraint).

In other words, the tendency shown on page 19 for brokers to mix positive and negative emotion across sentences is not a result of mixture within sentences. Sentences are positive or negative, not both. Brokers are different in combining negative sentences with positive sentences, which gives them a wide emotion aperture to their audience.

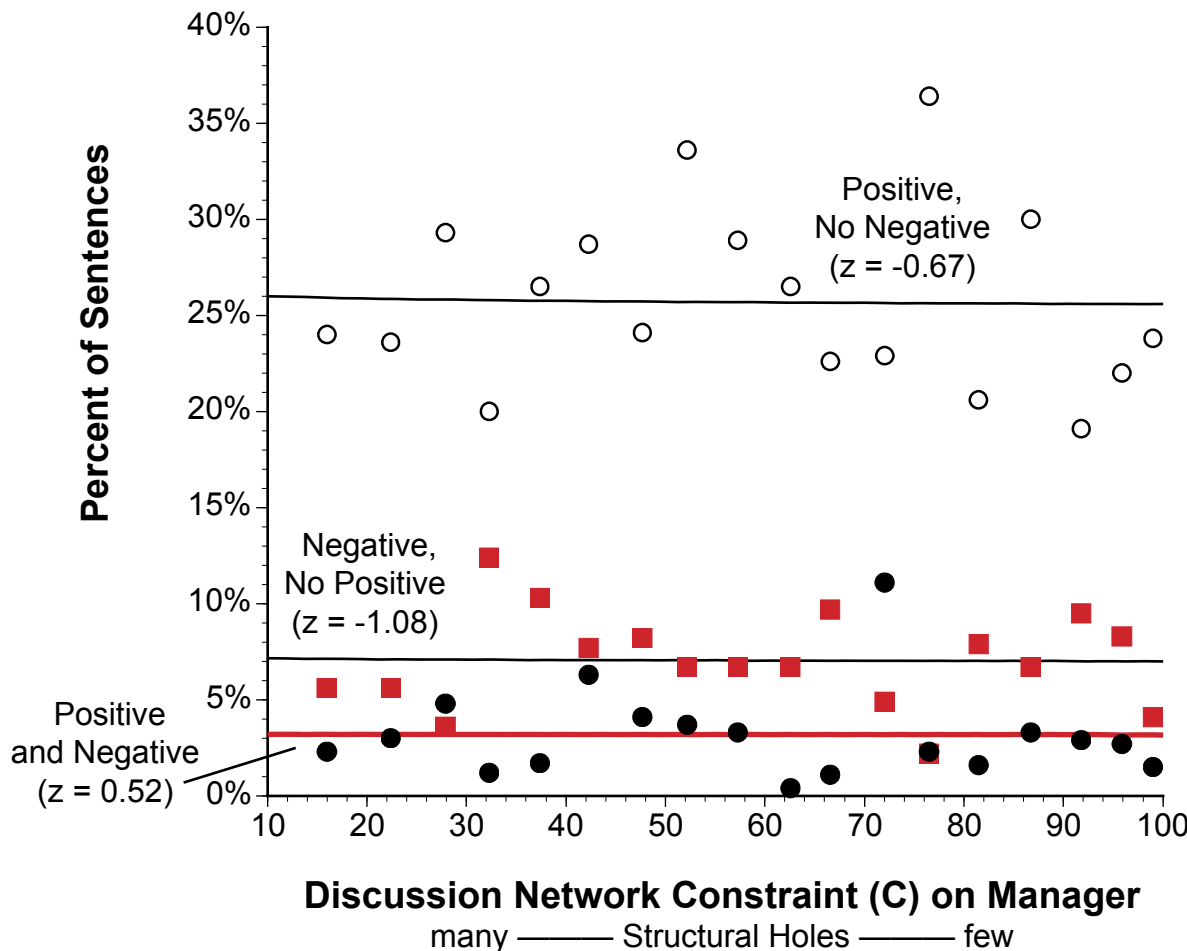

		Positive Words in Idea?		
Negative Words?			Total	
	No	Yes		
No	99	200	299	
Yes	35	121	156	
Total	134	321	455	

		Positive Words in Sentence?		
Negative Words?			Total	
	No	Yes		
No	1389	543	1932	
Yes	149	51	200	
Total	1538	594	2132	

Appendix VI: Social Peers Defined by Structural Equivalence

Social comparison does not require direct communication. Ego is influenced by feelings of increased or decreased stimulation relative to peers, peers who need not be people with whom ego talks.

$$\frac{\text{what ego } i \text{ currently feels}}{\text{actual stimulus to peer } j}$$

multiplier $\left(\frac{X_i^v}{X_j} \right) W_{ij}$

Network weight w_{ij} defines extent to which j is peer to i where $0 \leq w_{ij} \leq 1$, and $\sum_j w_{ij} = 1$.

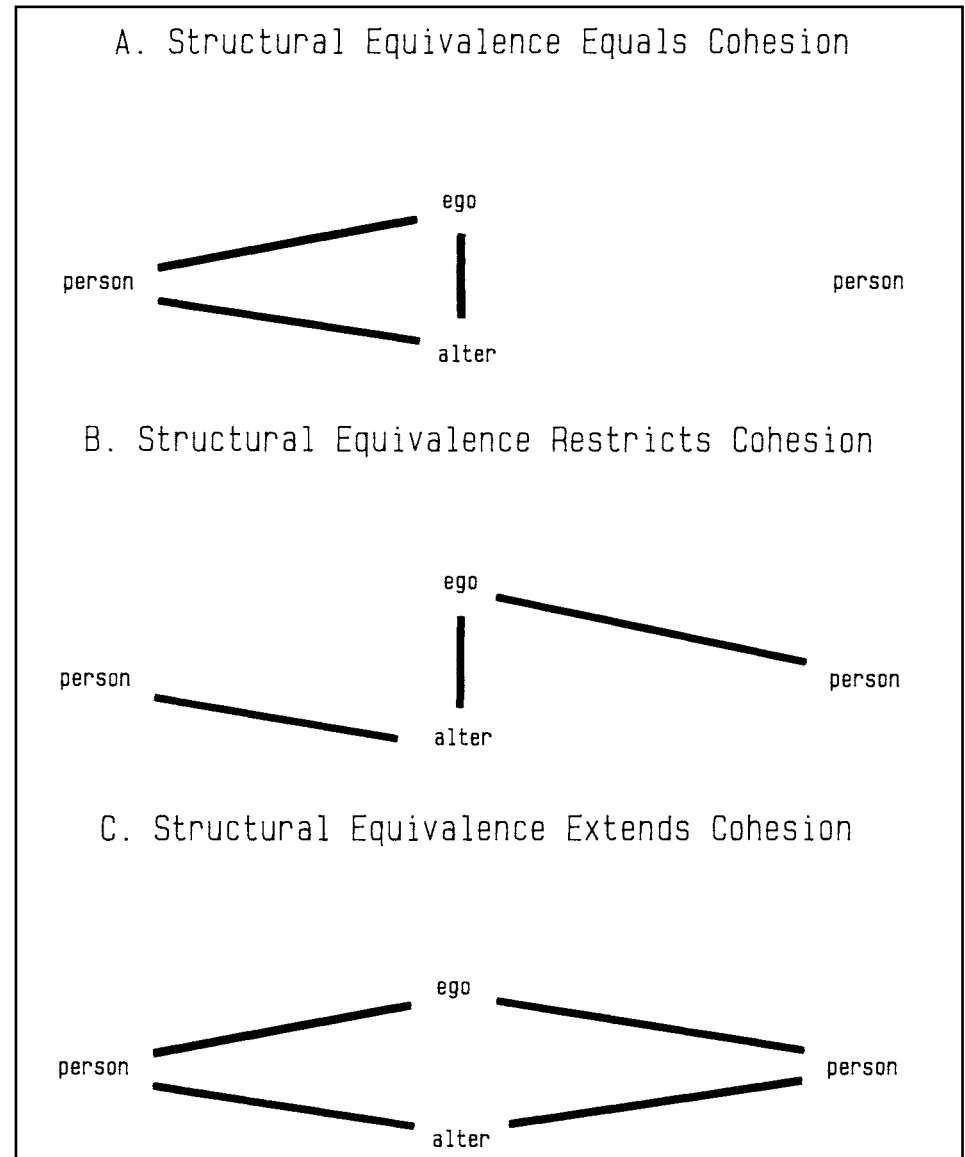

Expression is from page 9 of this handout. Figure is from Burt, "Social contagion and innovation: cohesion versus structural equivalence," (1987, AJS). See next pages for details on "structural" and "role" equivalence in a network. Ego in network A corresponds to the marketing individual contributors in the hypothetical organization on the next page. Ego in network B corresponds to the four group leaders on the next page. Ego in network C corresponds to the three salesmen on the next page.

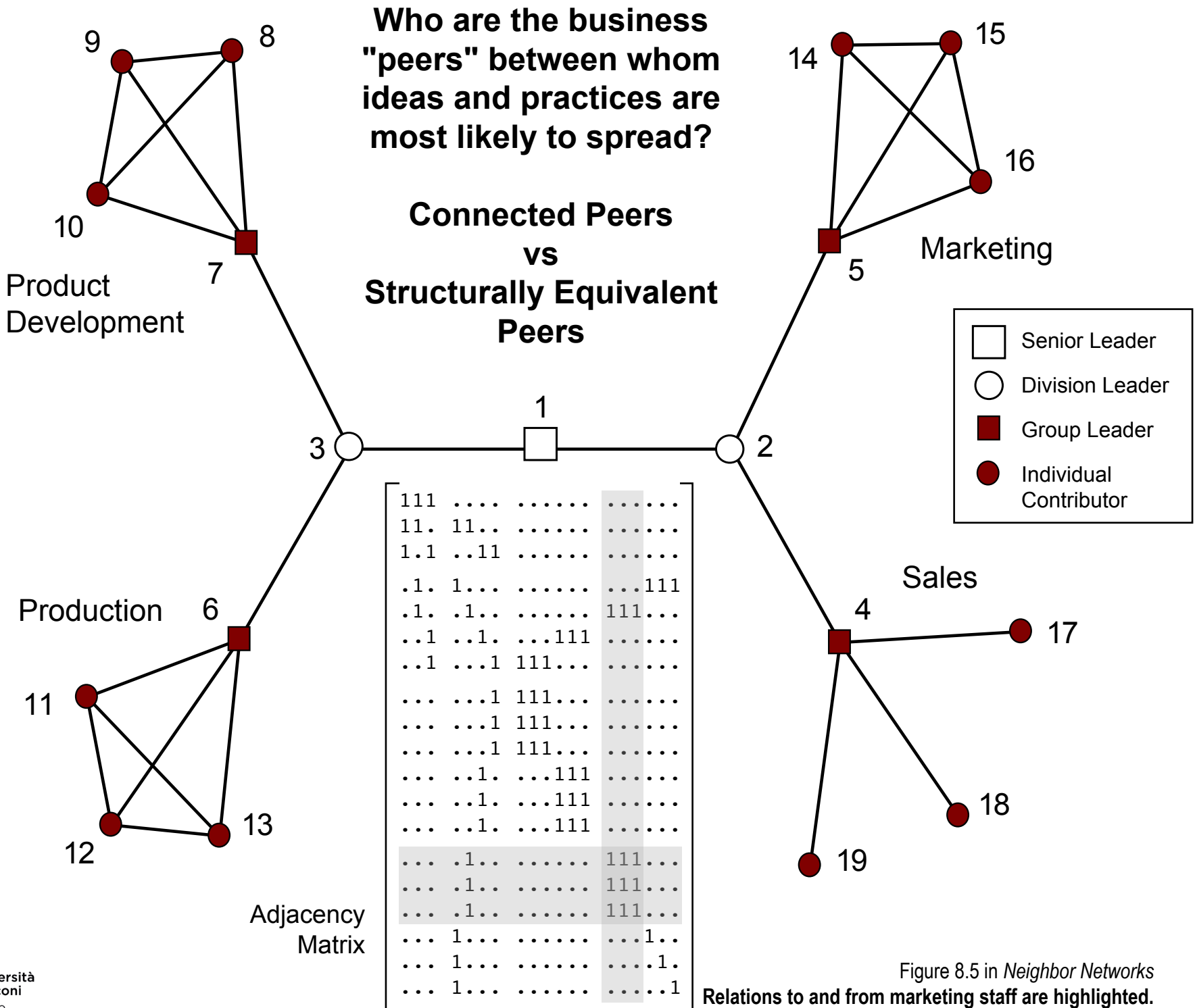

Figure 8.5 in *Neighbor Networks*

Spatial Map of Structurally Equivalent Peers in the Hypothetical Organization

This is a multidimensional scaling of structural equivalence distances between people in the hypothetical organization on the previous page (Kruskal stress = .048; distances are given on page 326 in *Neighbor Networks*)

Structural equivalence between i and j is measured by a distance, call it d_{ij} , which increases as each person k in a population has different relations with i and j , for example:

$$d_{ij}^2 = \sum_k (z_{ik} - z_{jk})^2 + \sum_k (z_{ki} - z_{kj})^2, \quad i \neq k \neq j$$

where z_{jk} is the strength of connection from j to k . Distance d_{ij} is zero when i and j have identical relations with everyone else in the organization.

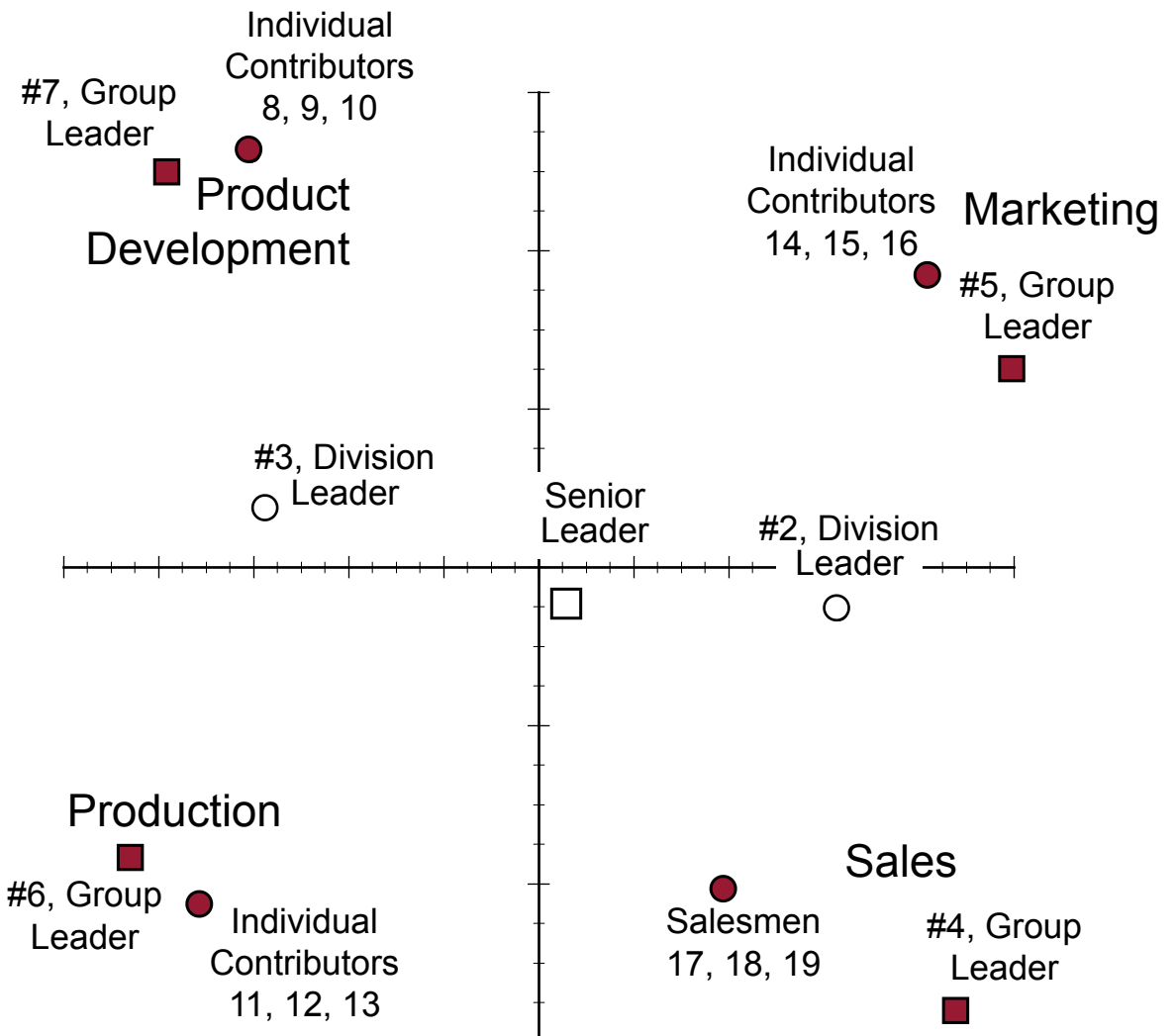

Figure 8.6 in *Neighbor Networks*

Spatial Map of Role Equivalent Peers in the Hypothetical Organization

This is a multidimensional scaling of the role equivalence distances between people in the organization (Kruskal stress = .004; distances are given on page 326 in *Neighbor Networks*). Compare this role space to the structural equivalence space on the previous page.

The distance between the role that individual j plays in a network and the role that i plays is given as follows:

$$d_{ij}^2 = \sum_k (t_{jq} - t_{iq})^2,$$

where q varies from 1 to 36 across kinds of triads (next page) and t_{jq} is a count of the frequency with which individual j is in the q th kind of triad (the t_{jq} for the division leaders are given to the right). Distance d_{ij} is zero when i and j play identical roles in their immediate networks.

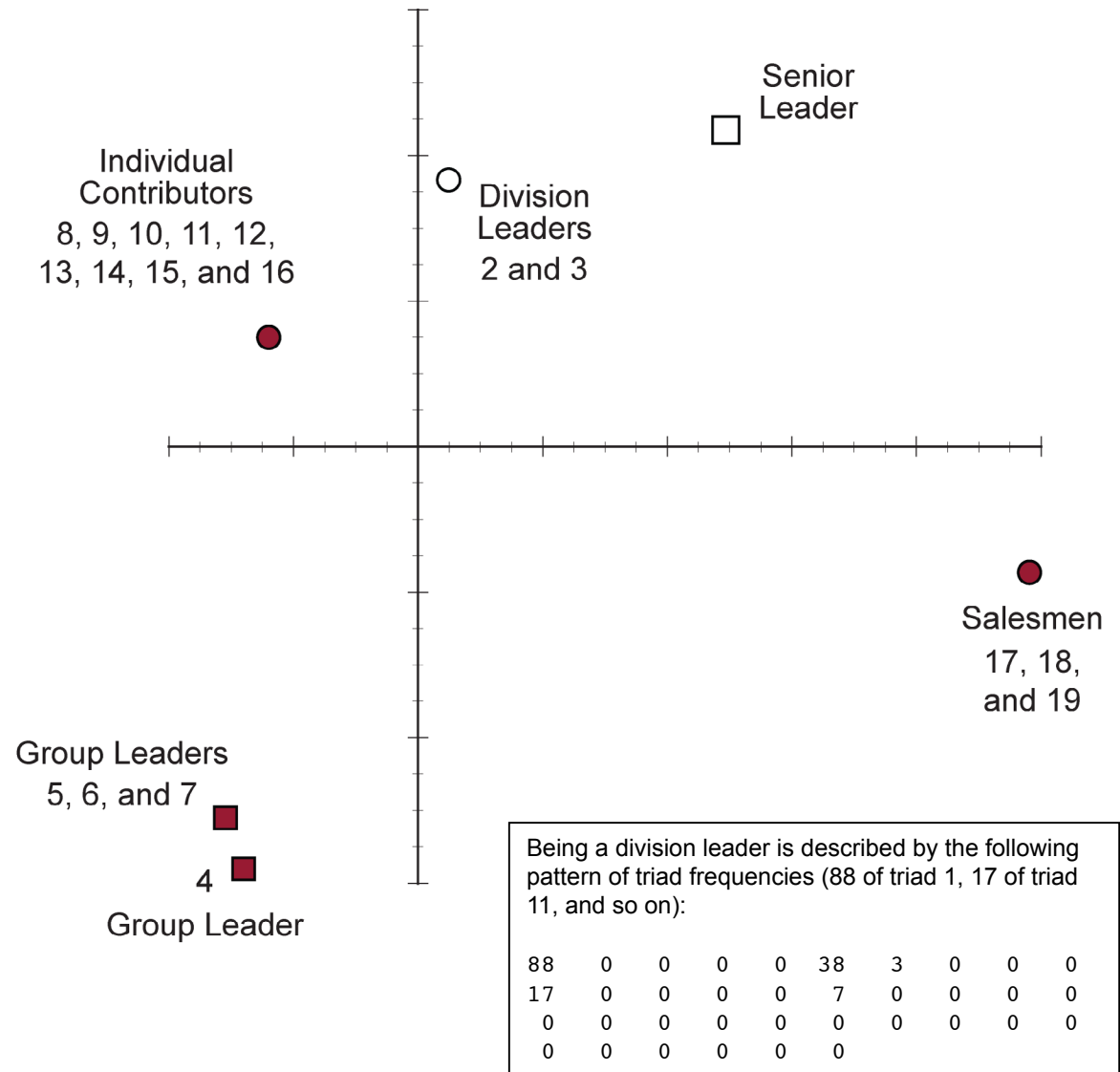

Figure 8.10 in *Neighbor Networks*

Interaction Triads Defining Ego's Role in a Network



Ego's Relations with Alters	RELATIONSHIP BETWEEN ALTERS		
	Null Between Alters	Mutual Between Alters	Asymmetric Between Alters
Null	1. 	11. 	21.  or 
Cites One Alter	2. 	12. 	22.  31. 
Cites Both Alters	3. 	13. 	23.  or 
Cited by One Alter	4. 	14. 	24.  32. 
Cited by Both Alters	5. 	15. 	25.  or 
Mutual with One Alter	6. 	16. 	26.  33. 
Mutual with Both Alters	7. 	17. 	27.  or 
Chain A	8. 	18. 	28.  34. 
Chain B	9. 	19. 	29.  35. 
Chain C	10. 	20. 	30.  36. 

Figure G8 in *Neighbor Networks*

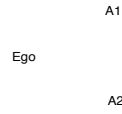
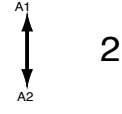
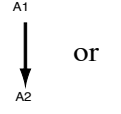
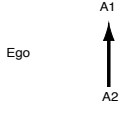
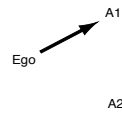
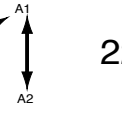
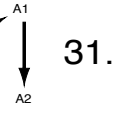
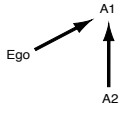
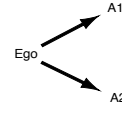
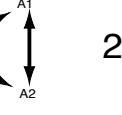
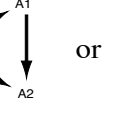
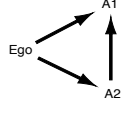
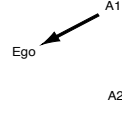
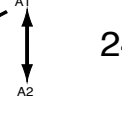
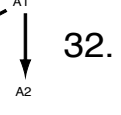
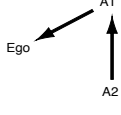
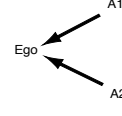
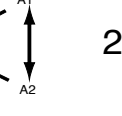
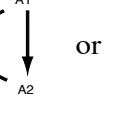
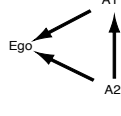
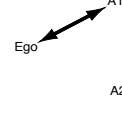
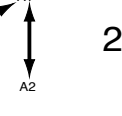
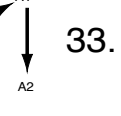
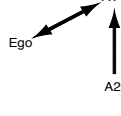
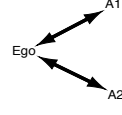
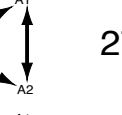
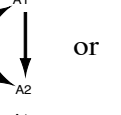
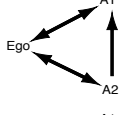
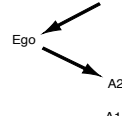

Brokers Among Scottish Knitwear Producers More Often Benchmark against Firms Outside Their Own Group

Cites Outside Own Segment?

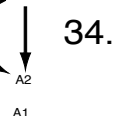
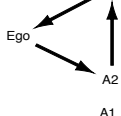
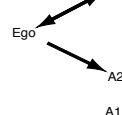
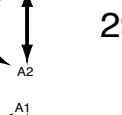
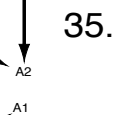
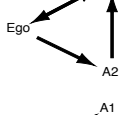
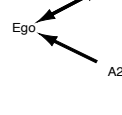
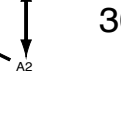
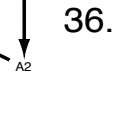
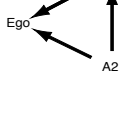
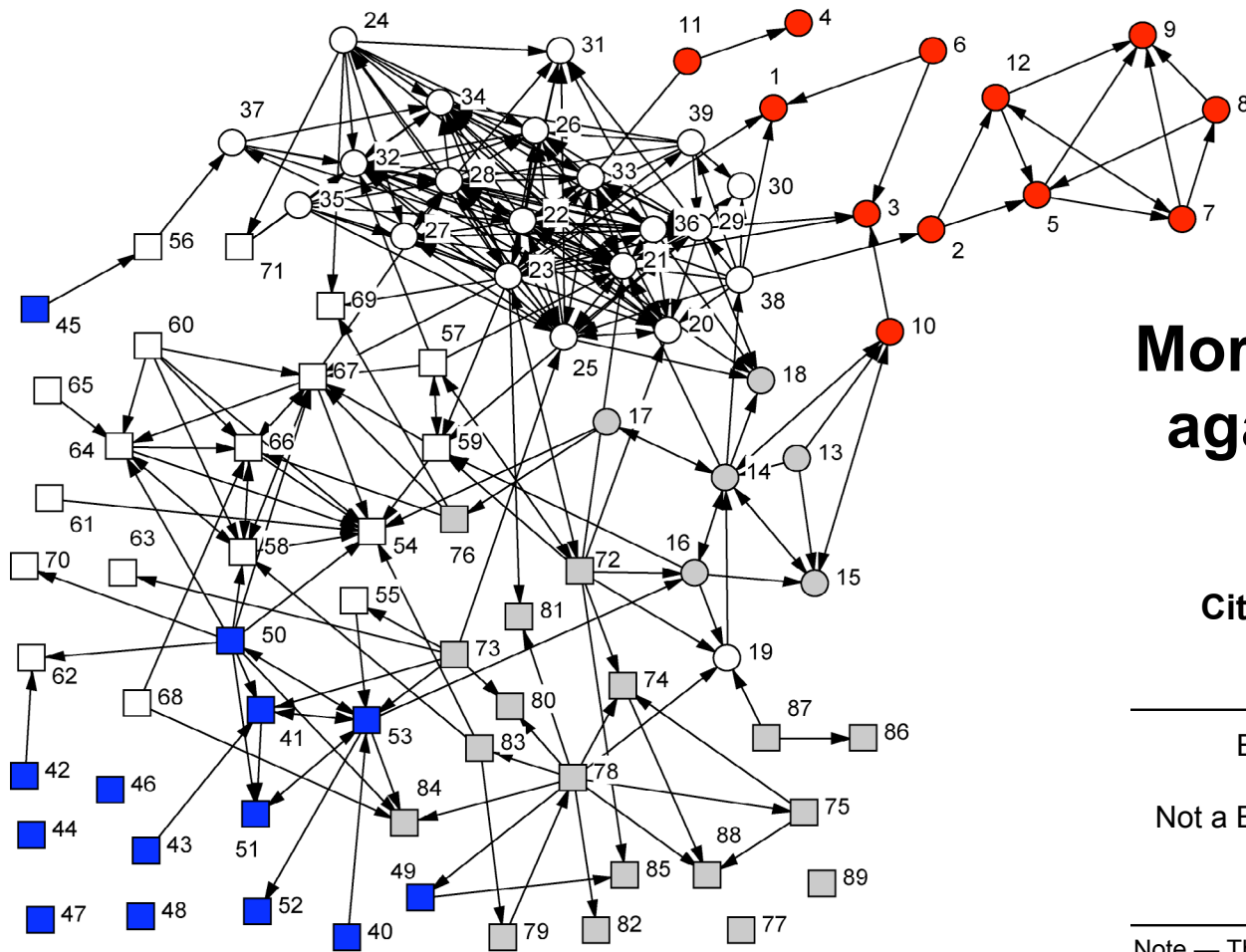
	No	Yes	Total
Broker	29	25 46%	54
Not a Broker	28	7 20%	35
Total	57	32	89

Note — The data and market segments are from Porac et al. (1995: 227). Lines indicate ego in 1990 citing another company that ego takes into account in pricing and marketing. Brokers above have below-average network constraint. “Yes” means ego cited one or more companies in another market segment as a monitored competitor. The chi-square for the table is 6.38, and logit test statistic for log network constraint predicting external cite is -3.13 ($P \sim .01$).

Market Segments:

- Up-Market
- High-Fashion Handframers
- Mid-Marketers
- Traditional Handframers
- Mass-Marketers
- Handknitters

Baseline Influence Model — Network is a Plumbing System of Information Pipes:

Interpersonal influence between closely connected people is often cited to explain how ideas, practices, and products spread through word of mouth, or "buzz" marketing.

Average Z-Score Difference across Study Populations

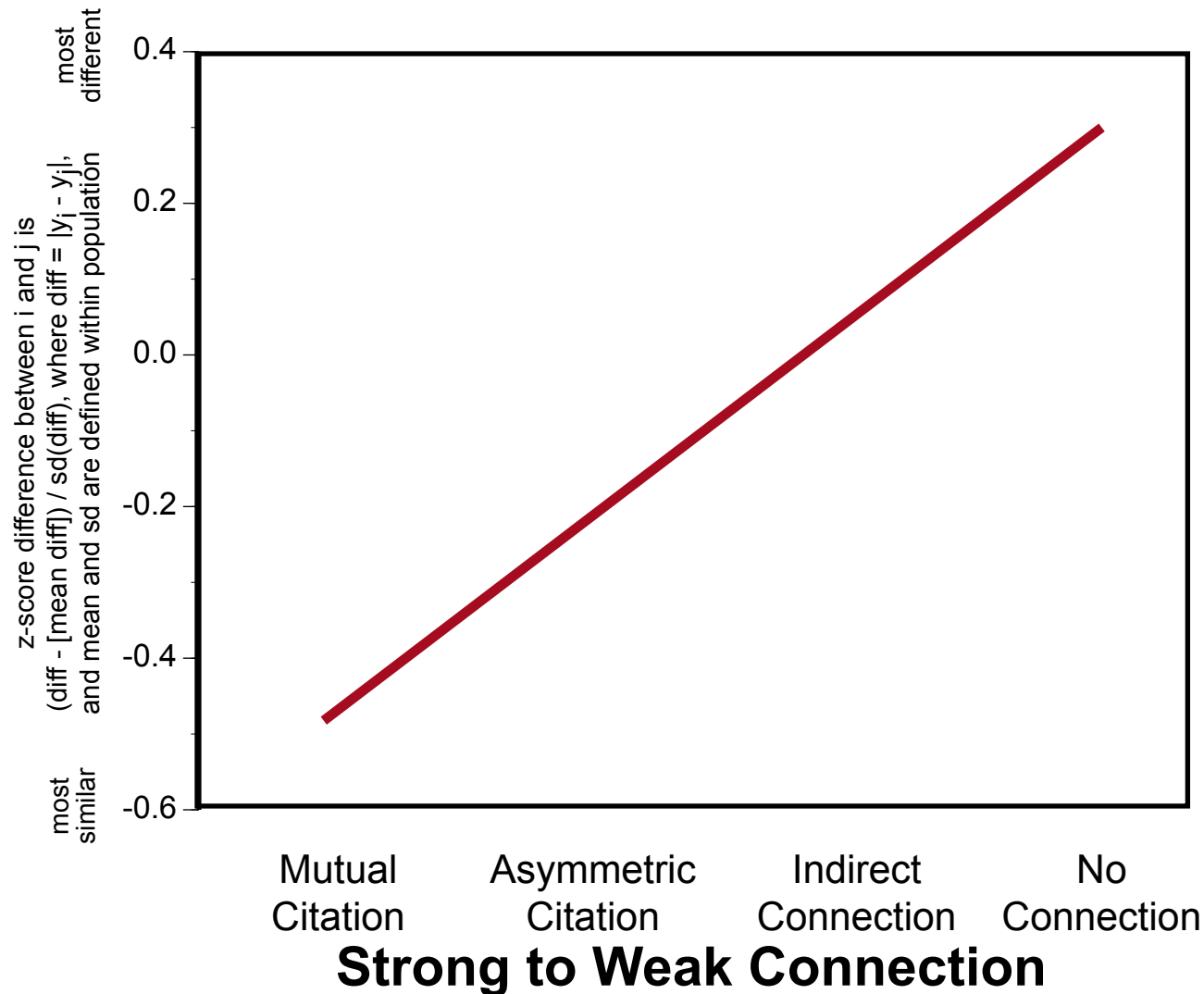

Lazarsfeld, Berelson, and Gaudet (1944, People's Choice)

Festinger, Schachter, and Back (1950, Social Pressures in Informal Groups)

Katz and Lazarsfeld (1955, Personal Influence)

Coleman, Katz, and Menzel (1966, Medical Innovation)

Christakis and Fowler (2009, Connected [Framingham studies])

Aral, Muchnik, and Sundararajan (2009, PNAS, "Distinguishing influence-based contagion from homophily-driven diffusion in dynamic networks")

Much of Classic Research is about Influence Between Structurally Equivalent Peers

Start with the 1898 Triplett experiment, often said to be the first experiment in social psychology

The initial empirical evidence of social influence was between people who were not connected, but were structurally equivalent in several ways.

For example, Triplett's (1898) analysis of why people exert themselves is often deemed the first experiment in social psychology (Stube, 2005). The results describe men competing in bicycle races, and children competing on the speed with which they can wind a fishing reel.

The bicyclists and children are structurally equivalent — standing in common relation to the rule-making authority, the goal, one another, and non-competing spectator elements in the environment. Though not talking with one another, the competitors influence one another. Triplett (1898:533) shows that people work faster when they are pitted against a competitor: “the bodily presence of another contestant participating simultaneously in the race serves to liberate latent energy not ordinarily available.”

The below two regression equations predict task time for the children in seconds from Triplett's data (1898:521-522; t-tests in parentheses, adjusted for repeated observations of the same children). The first row describes all 40 children across six trials ($R^2 = .44$). The second describes the 20 children Triplett identified as affected positively by a competitor ($R^2 = .53$). Having a competitor increased the average child's task speed by a second (3% gain on an average of 38.3 seconds) and increased speed by two and a half seconds for the average positively-affected child (6% gain on an average of 41.9 seconds). The control variables in the equations show that the children became faster on successive trials, girls were about the same speed as boys, older children were able to do the task more quickly, and left-handed children were disadvantaged by the equipment being set up for right-handed children.

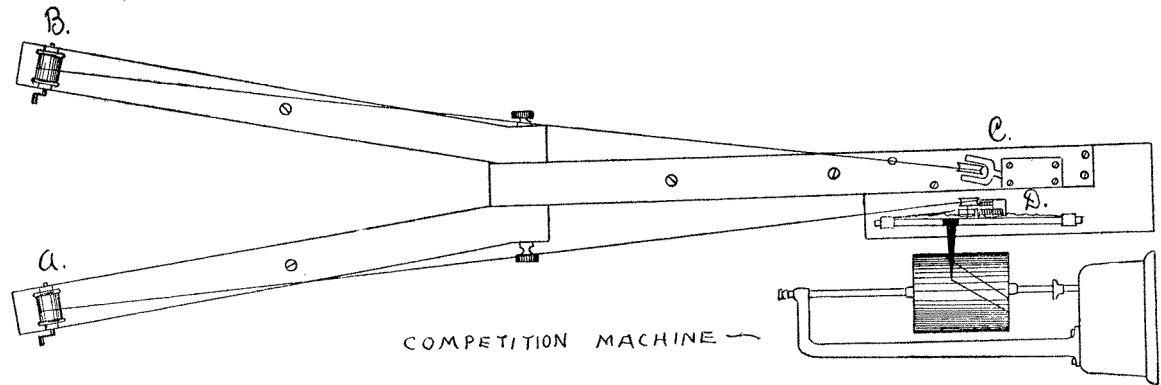

	Constant	Competitor	Trial (1-6)	Female	Age (8-17)	Left-handed
All	66.90	-1.04 (-2.77)	-1.17 (-7.15)	0.55 (0.36)	-2.14 (-5.06)	11.90 (5.86)
Positive	70.54	-2.67 (-8.38)	-1.66 (-7.22)	0.56 (0.25)	-2.03 (-3.80)	9.15 (4.37)

were about the same speed as boys, older children were able to do the task more quickly, and left-handed children were disadvantaged by the equipment being set up for right-handed children.

Text and table are from pages 334-335 of *Neighbor Networks*. Figure is from page 519 of Norman Triplett (1898), "The dynamogenic factors in pacemaking and competition," *American Journal of Psychology*.

1935 Sherif Experiment

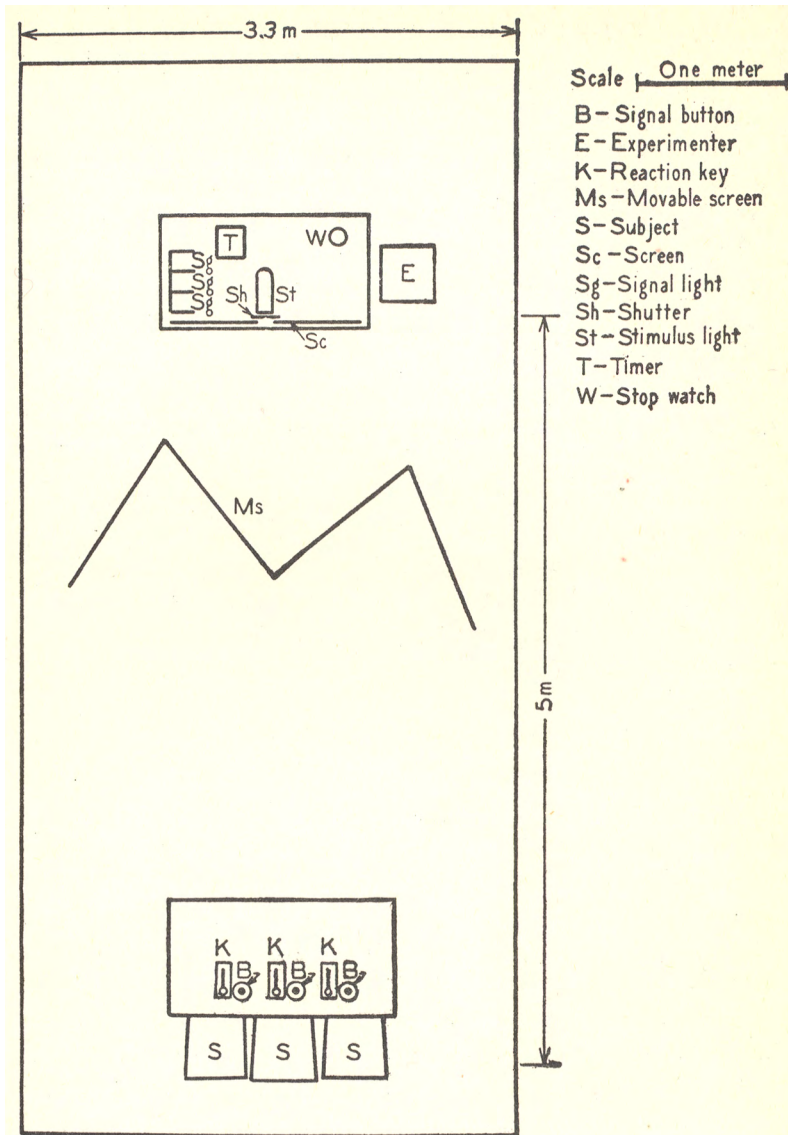

FIG. 3.—Plan of Experimental Room.

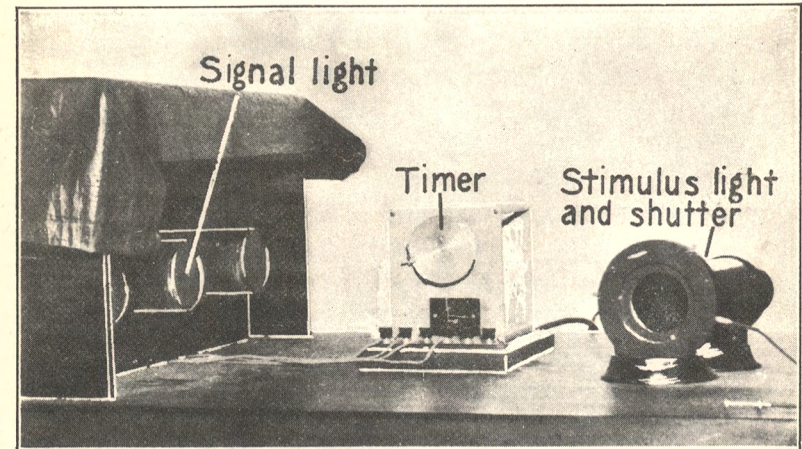
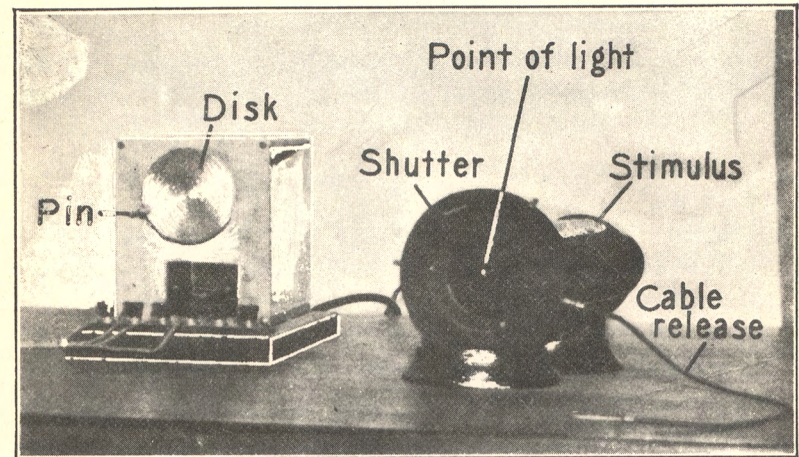

FIG. 4.—(Above) Apparatus for individual trials with screen removed. (Below) Apparatus for group experiments with screen removed.

1951 Asch Experiment: Perception in Social Context



12 trials for each of 50 subjects (college students, with 6 confederates pictured above)

74% conform at least once (37/50)

Conformity on 32% of trials (192/600)

Variations:

99% accurate when subject is alone.

3% conformity with 1 confederate present.

13% conformity with 2 confederates present.

33% conformity with 3 confederates present.

35% conformity with 4 confederates present.

32% conformity with 8 confederates present.

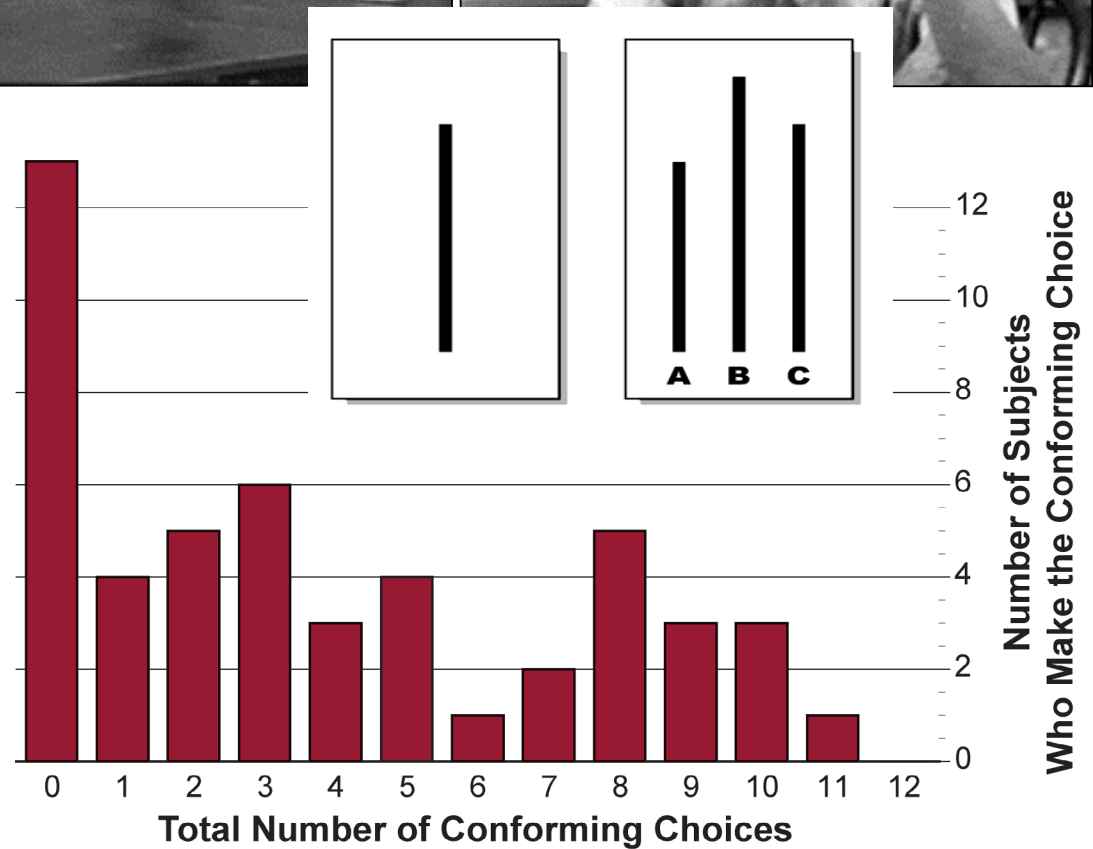

Appendix G in *Neighbor Networks* contains an overview of social context affecting perception. This slide is Figure G1 in that appendix. Also see "The shadow of other people" on my research website (2010, *The Connected Customer*).

Updating Baseline Model to Fit the Facts: Personal Influence Has a Z-Pattern in which Network Brokers are the Familiar "Opinion Leaders" in Traditional Market Research

Average Z-Score Difference across Study Populations

z-score difference between i and j is $(\text{diff} - [\text{mean diff}] / \text{sd}(\text{diff}))$, where $\text{diff} = |y_i - y_j|$, and mean and sd are defined within population

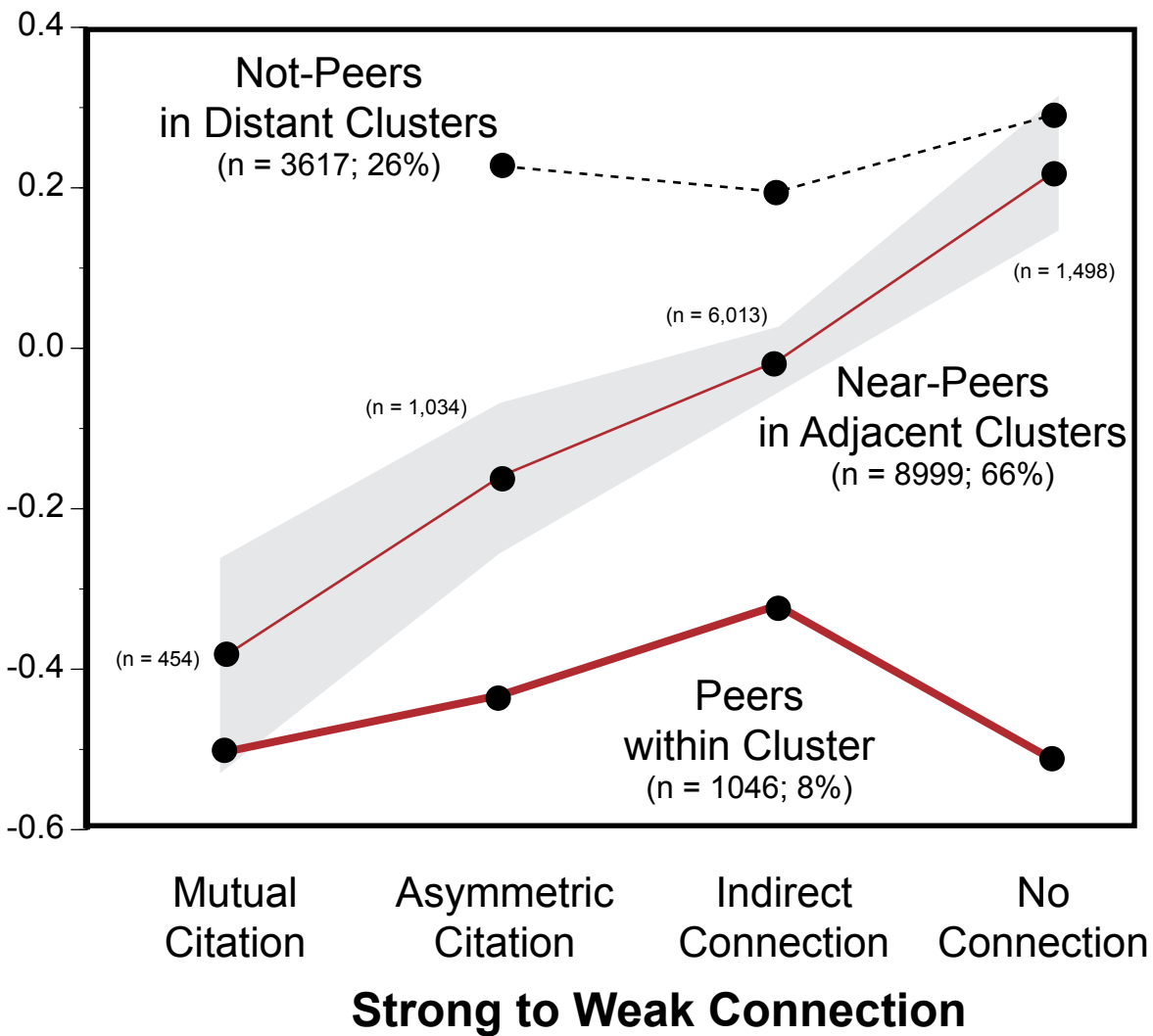

Shaded area around thin line in the graph is confidence interval defined by three times the routine standard error of each mean for the near-peers.